

TABLE OF CONTENTS

1	FIGURE NUMBER SYSTEM	1~2
2	SELF-LUBRICATED PLUG VALVE	3~6
3	PRESSURE BALANCE LUBRICATED PLUG VALVE	7~11
4	TORQUE VALUE CHART	12
5	THE STATIC STRESS ANALYSIS	12
6	INSTALLATION, MAINTENANCE AND OPERATING INSTRUCTIONS	13

FIGURE NUMBER SYSTEM

1. VALVE TYPE	CPS=SELF-LUBRICATED PLUG VALVE (PLUG / SOFT SEAT VALVE) CPM=PRESSURE BALANCE LUBRICATED PLUG VALVE (PLUG / METAL SEAT VALVE)		
2. SIZE	02=2" 21=2 1/2" 03=3" 04=4" 05=5" 06=6" 08=8"	10=10" 12=12" 14=14" 16=16" 18=18" 20=20" 24=24"	26=26" 28=28" 30=30" 32=32" 36=36" 40=40" 42=42"
3. PORT	V=VENTURI R=CONVENTIONAL F=FULL		
4.PRESSURE	01=ANSI CLASS 150 03=ANSI CLASS 300 06=ANSI CLASS 600	09=ANSI CLASS 900 15=ANSI CLASS 1500 25=ANSI CLASS 2500	
5. ENDS	RF=RAISED FACE FLANGED JF=RTJ FLANGED RW=RAISED FACE FLANGED × WELDED END JR=RTJ × RAISED FACE FLANGED JW=RTJ × WELDED END	BW=BUTT WELDED FF=FLAT FACE NT=NPT FEMALE SW=SOCKET WELDED	
6. BODY MATERIAL	01=ASTM A216 WCB/A105 02=ASTM A352 LCC/A350 LF2 03=ASTM A351 CF8M/A182 F316 04=ASTM A890 4A/A182 F51 05=ASTM A182 F55 06=ASTM A105N 07=ASTM A216 WCB+ENP/A105+ENP 08=ASTM A395 09=ASTM A351 CF8/A182 F304	10=ASTM A217 WC6/A182 F11 11=ASTM A217 C5/ASTM A182 F5 12=ASTM A351 CF3M/A182 F304L 13=ASTM A351 CF3M/A182 F316L 14=ASTM M35-1/B 564 N04400 15=ASTM A351 CN7M 16=ASTM A217 C12/A182 F9 17=ASTM A217 WC9/A182 F22 18=ASTM A 126 B	19=ASTM A216 WCC 20=ASTM A352 LCB 21=ASTM A217 C12A/A182 F91 22=ASTM A182 F12 23=ASTM A182 F321 24=ASTM A217 WC1 25=ASTM B61/B62 26=ASTM A 694 F60 27=ASTM A494 N-7M/CW-6MC 28=ASTM A487 Gr 9 29=ASTM A182 F347 30=ASTM A351 CF8C 31=ASTM A182 904L 32=ASTM A182 F304H 33=ASTM A890 5A/A182 F53

7.PLUG MATERIAL	S2=ASTM A351 CF8/A182 F304	S6=ASTM A182 F55	S10=AISI 4140+ENP
	S3=ASTM A351 CF8M/A182 F316	S7=ASTM A351 CF3M/A182 F316L	E1=BODY MATERIAL+1MIL ENP
	S4=ASTM A276 410/A182 F6a	S8=ASTM A351 CF3/A182 F304L	E3=BODY MATERIAL+3MIL ENP
	S5=ASTM A890 4A/A182 F51	S9=ASTM A564 630	E2=BODY MATERIAL+PTFE

8.PLUG MATERAIL	P=PTFE / TEFLON
------------------------	-----------------

9.OPERATOR	L=LEVER / WRENCH	E=ELECTRICAL OPERATOR
	G=GEAR BOX	P=PNEUMATIC OPERATOR
	B=BARE STEM	H=HYDRAULIC OPERATOR
	W=HANDWHEEL	S=SOLENOID OPERATOR

10.MATERIAL TYPE	C=CASTING	F=FORGED
-------------------------	-----------	----------

1.PART NUMBER EXAMPLE:

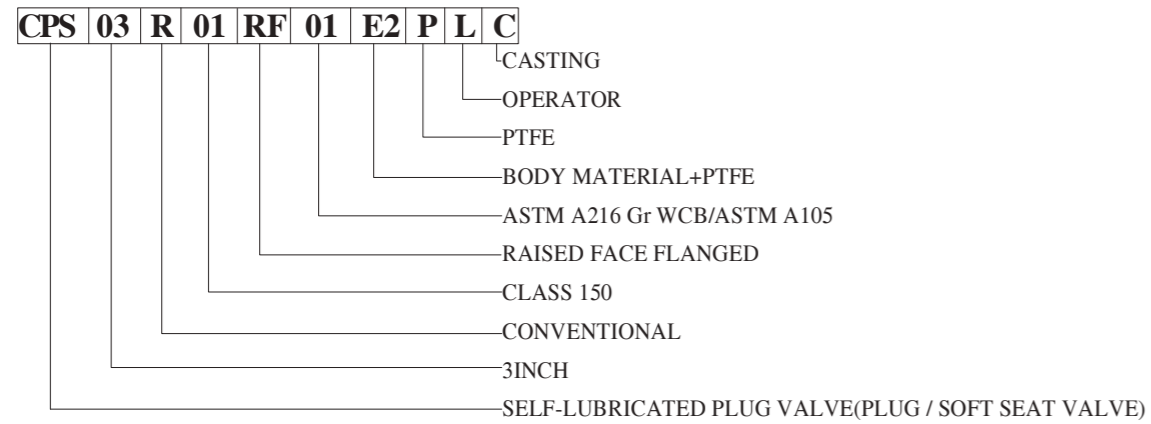

2.SERIES NUMBER EXAMPLE:

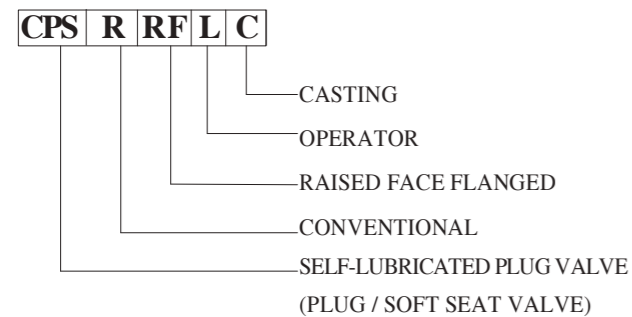

SELF-LUBRICATED PLUG VALVE

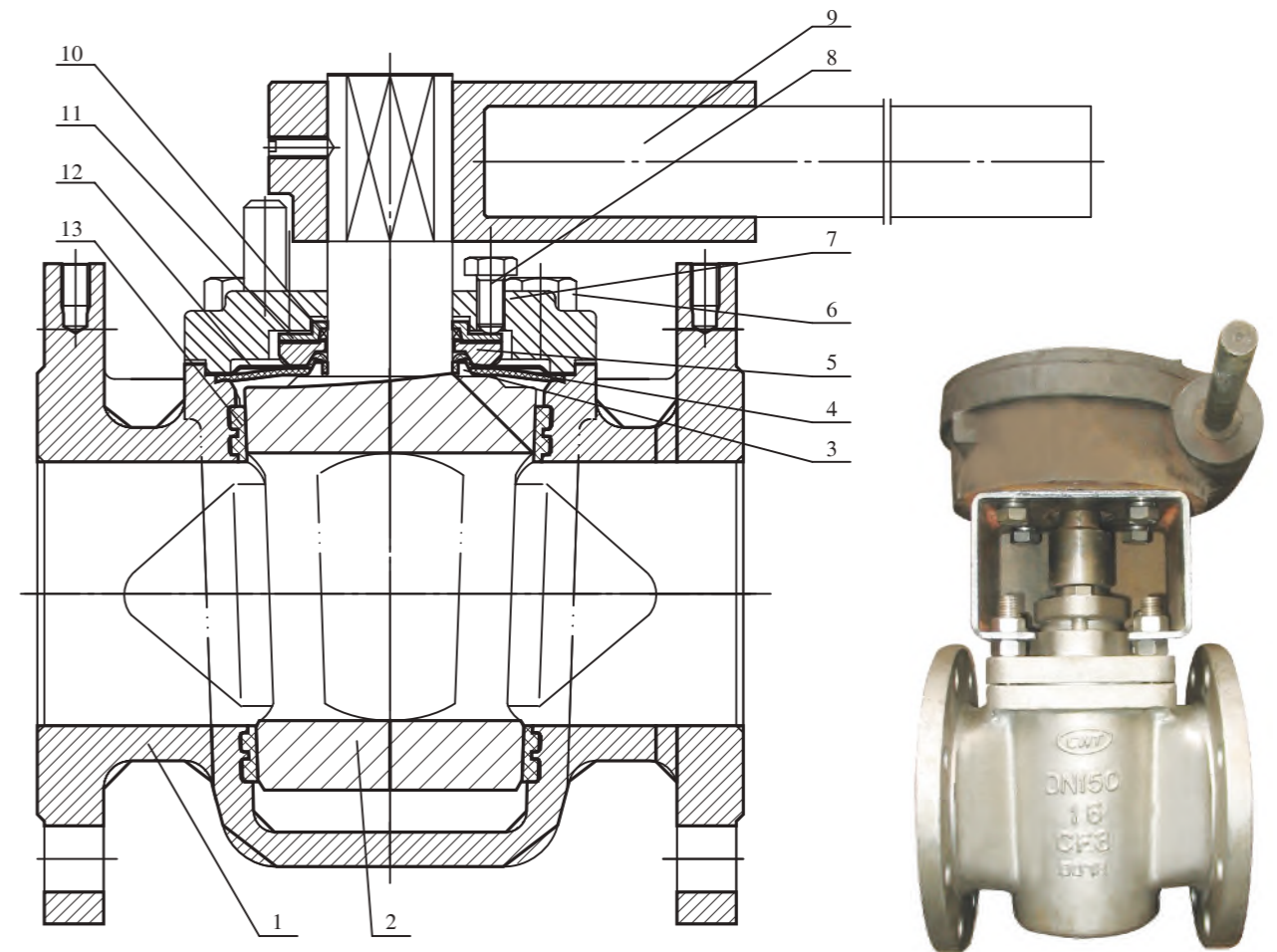

DESIGN FEATURES:

- THE INLET AND OUTLET ARE DESIGNED AS DOUBLE-GROOVE METAL-SLIP SEALING STRUCTURE, WHICH CAN NOT ONLY MAKE SLEEVE FIRMLY FIXED IN THE BODY WITHOUT ANY ROTATION, BUT ALSO ABSORB THE MINOR DEFORMATION OF SLEEVE CAUSED BY TEMPERATURE CHANGE.
- THE PLUG PRODUCES A CERTAIN FRICTION AGAINST THE SLEEVE WHEN ROTATION, WHICH MAKES THE METAL-SLIP AUTO-CLEANED AND FURTHER IMPROVE THE SERVICE LIFE OF SEALING FACE.
- PTFE SLEEVE HAS A LOW COEFFICIENT OF FRICTION AND CAN ACT AS A LUBRICANT.
- PLUG AND STEM ARE DESIGNED AS AN INTEGRATED PART.

SELF-LUBRICATED PLUG VALVE

STANDARDS:

- DESIGN AND MANUFACTURE: API 6D / API 599
- FACE TO FACE DIMENSIONS: API 6D / ASME B16.10
- FLANGED ENDS DIMENSIONS: ASME B16.5
NPS 1/2"~24"
- PRESSURE-TEMPERATURE RATINGS: ASME B16.34
- PRESSURE: CLASS 150~CLASS 300
- SIZE: NPS 1/2"~16"



BILL OF MATERIAL (PARTIAL)

ITEM	PART NAME	STANDARD	LOW TEMPERATURE	STAINLESS STEEL
1	BODY	ASTM A216 WCB	ASTM A352 LCC	ASTM A351 CF8M
2	PLUG	ASTM A351 CF8	ASTM A351 CF8	ASTM A351 CF8M
3	THRUST WASHER	RPTFE		
4	SEALING DIAPHRAGM	PTFE		
5	ADJ. GLAND	ASTM A276 410	ASTM A276 304	ASTM A276 316
6	BONNET BOLT / NUT	ASTM A193 B7(B7M) / A194 2H(2HM)	ASTM A320 L7(L7M) / A194 7(7M)	ASTM A193 B8M / A194 8M
7	BONNET	ASTM A216 WCB	ASTM A352 LCC	ASTM A351 CF8M
8	ADJ. BOLT	ASTM A193 B7(B7M)	ASTM A320 L7(L7M)	ASTM A193 B8M
9♦	LEVER	CARBON STEEL		
10	PACKING	GRAPHITE		
11	GLAND	ASTM A276 410	ASTM A276 304	ASTM A276 316
12	METAL DIAPHRAGM	SS304	SS304	SS316
13	SLEEVE	PTFE / PFA / FEP(F46)		

♦GEAR OPERATOR, ELECTRICAL OPERATOR, PNEUMATIC OPERATOR, HYDRAULIC OPERATOR ETC. ARE AVAILABLE
NOTE: OTHER MATERIALS ARE AVAILABLE UPON REQUEST.

SELF-LUBRICATED PLUG VALVE

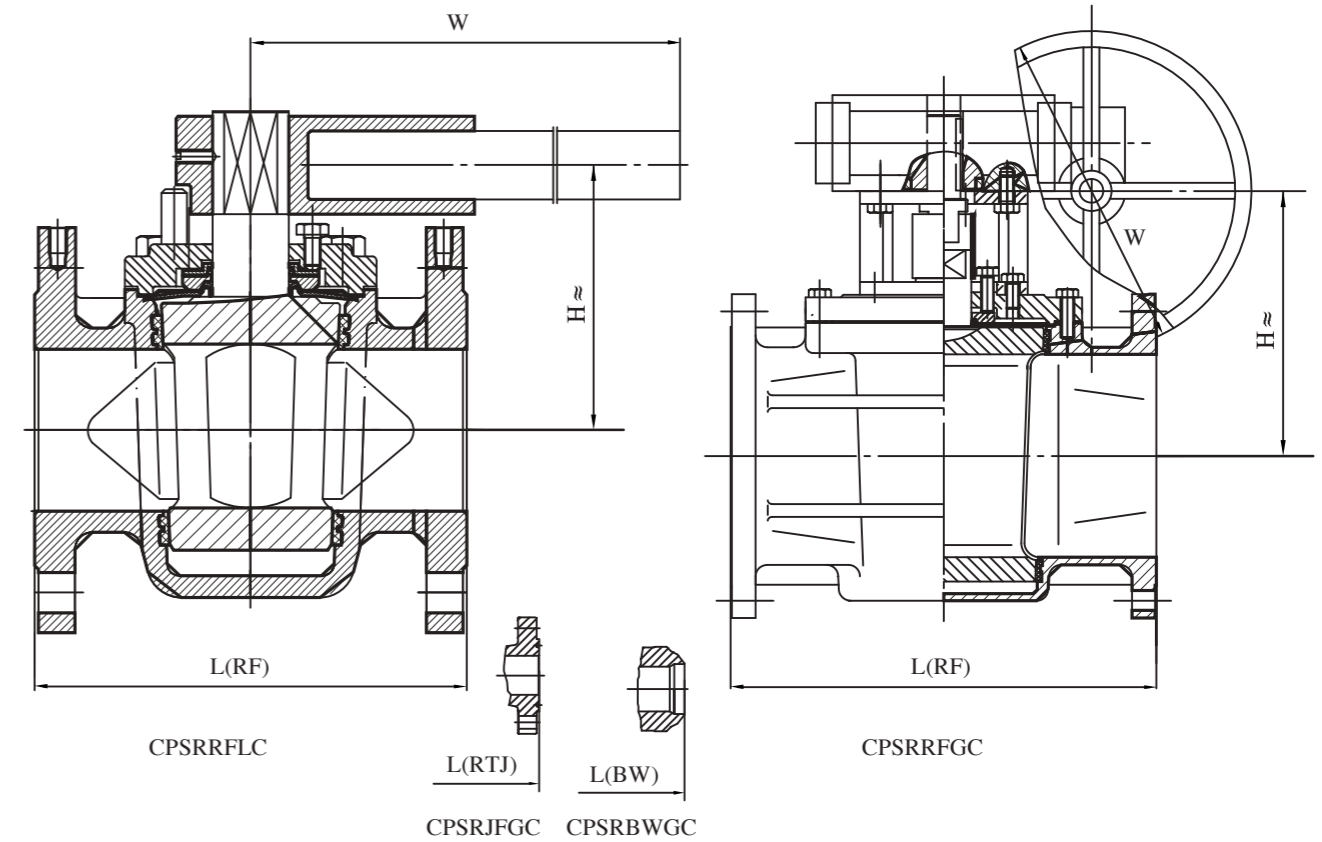

CLASS 150

NPS	in	1-1/2	2	2-1/2	3	4	5	6	8	10	12	14	16
DN	mm	40	50	65	80	100	125	150	200	250	300	350	400
L(RF)	mm	165	178	191	203	229	254	267	292	330	356	381	762
L(BW)	mm	241	267	305	330	356	381	457	521	559	635	762	762
L(RTJ)	mm	178	191	203	216	241	267	279	305	343	368	394	775
H	mm	110	122	130	145	230	345	290	330	390	420	460	530
W	mm	200	200	400	600	300	300	300	300	400	400	450	710
WT(RF)	Kg	5	10	16	19	29	62	93	127	175	260	-	-

CLASS 300

NPS	in	1-1/2	2	2-1/2	3	4	5	6	8	10	12
DN	mm	40	50	65	80	100	125	150	200	250	300
L(RF)	mm	191	216	241	283	305	381	403	419	457	502
L(BW)	mm	241	267	305	330	356	381	457	521	559	635
L(RTJ)	mm	203	232	257	298	321	397	419	435	473	518
H	mm	110	122	135	150	240	285	310	355	390	460
W	mm	200	200	400	620	300	300	300	400	400	450
WT(RF)	Kg	10	12	18	23	61	100	148	166	212	333

GEAR OPERATOR FOR ≥ NPS 4

SELF-LUBRICATED PLUG VALVE

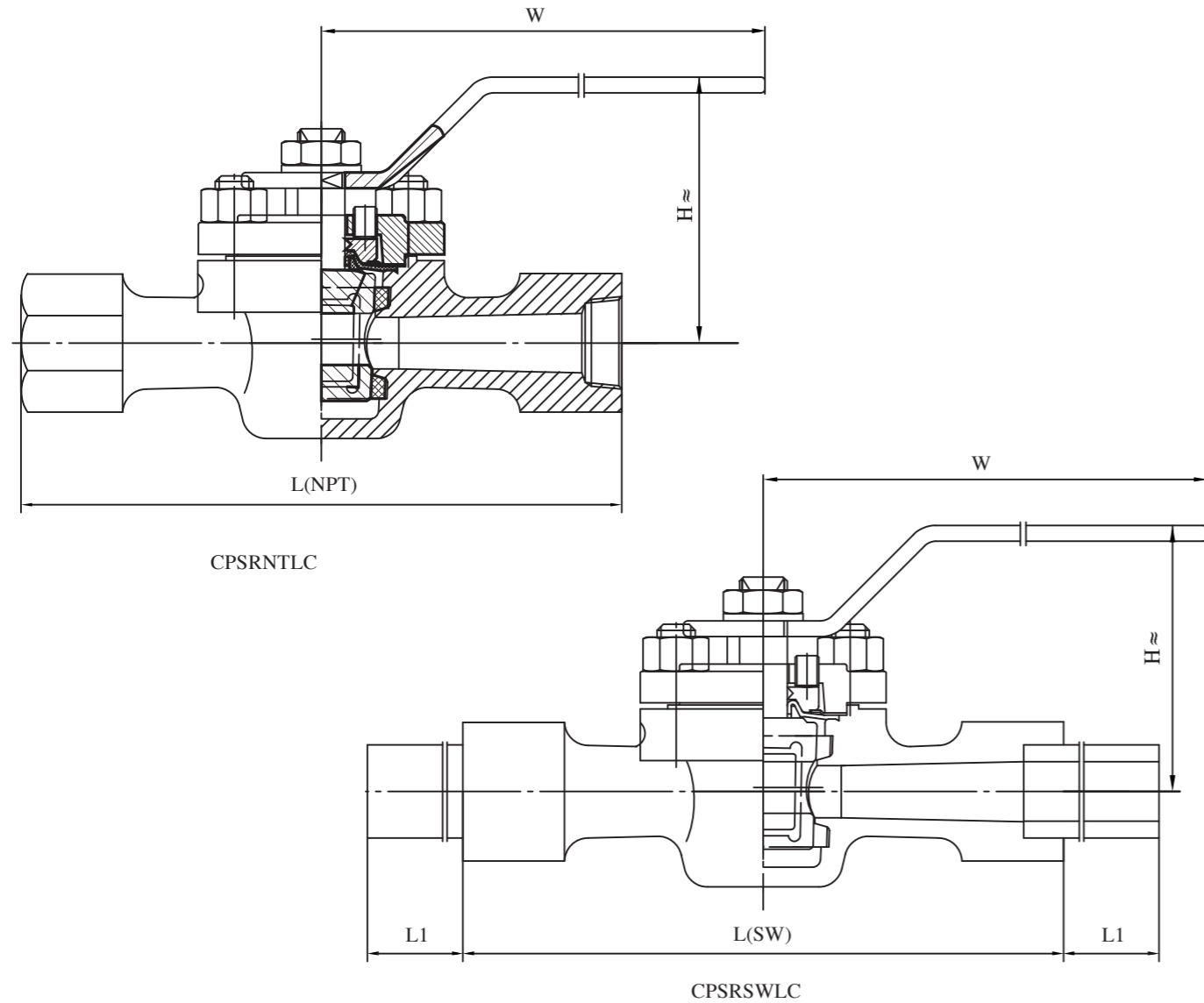

CLASS 150

NPS	in	1/2	3/4	1	1-1/2	2
DN	mm	15	20	25	40	50
L(NPT)	mm	115	115	119	150	165
L(SW)	mm	115	115	119	150	165
L1	mm	100	100	100	100	100
H	mm	85	85	100	100	122
WT(NPT)	Kg	2	2.5	4.5	5	9

PRESSURE BALANCE LUBRICATED PLUG VALVE

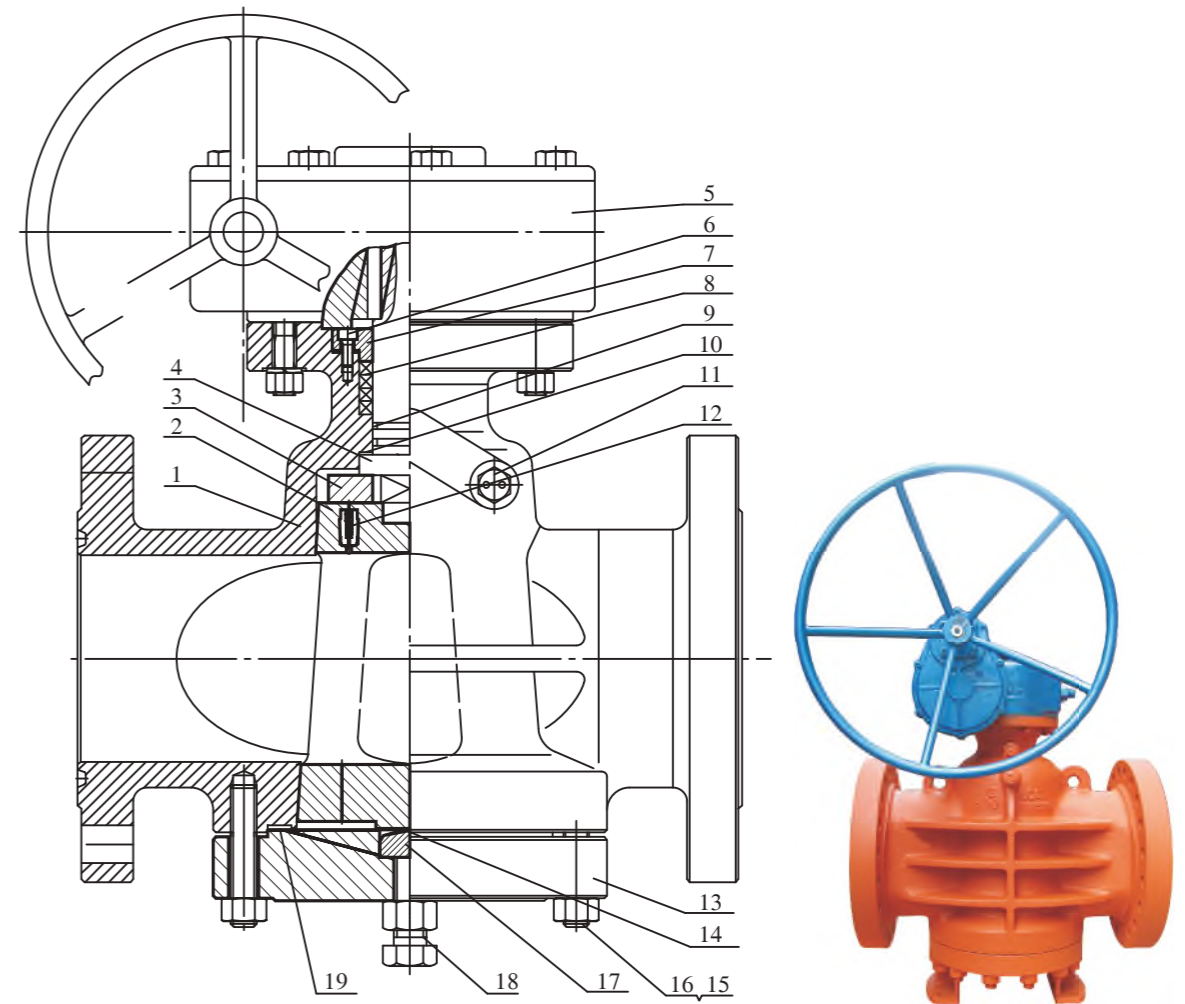

DESIGN FEATURES:

- THE INVERTED PLUG IS INSTALLED IN THE BODY.
- TO REDUCE THE FRICTION, THE LUBRICANT IS INJECTED INTO THE VALVE BODY TO FORM AN OIL FILM BETWEEN THE BODY AND PLUG, WHICH ENSURES SEALING PERFORMANCE AND FURTHER TO REDUCE THE TORQUE OF THE OPEN AND CLOSE OF THE VALVE.
- AT THE MOMENT OF OPENING VALVE, THE PRESSURE IN THE LOWER CAVITY OF THE BODY IS BALANCED WITH THE MEDIUM PRESSURE IN PIPELINE. THE PLUG IS FORCED DOWN BY THE HIGH PRESSURE OF GREASE FROM THE UPPER CAVITY, WHICH CAUSES A SMALL CLEARANCE BETWEEN BODY SEALING FACE AND PLUG, THUS THE TORQUE IS EFFECTIVELY REDUCED DURING PLUG'S ROTATION AND THE SEALING SURFACE IS ALSO PROTECTED.
- THERE IS AN ADJUSTABLE SCREW AT THE VALVE BOTTOM. IF THE WORKING TEMPERATURE HAS A BIG CHANGE, THE DEFORMED PLUG CAN BE ADJUSTED THROUGH THE SCREW, TO AVOID SEALING PAIR BEING STUCK OR REDUCING THE GAP OF SEALING SURFACE.
- THE PLUG IS HARDENED OR COATED WITH PTFE/ENP WHICH PROVIDES HIGH RESISTANCE TO ABRASION AND CORROSION OF SEALING FACE.
- THE SURFACE OF PLUG IS FINE GRINDED WITH THE SEALING FACE OF BODY TO LOWER THE TORQUE OF OPENING AND CLOSING.
- ANTI-STATIC AND FIRE SAFE DESIGN.

PRESSURE BALANCE LUBRICATED PLUG VALVE

STANDARDS:

- DESIGN AND MANUFACTURE: API 6D / API 599
- FACE TO FACE DIMENSIONS: API 6D / ASME B16.10
- FLANGED ENDS DIMENSIONS:
 - NPS 1/2"~24 ASME B16.5
 - NPS 26" ~36" ASME B16.47
- PRESSURE-TEMPERATURE RATINGS: ASME B16.34
- PRESSURE: CLASS 150~CLASS 1500
- SIZE: NPS 2"~36"



BILL OF MATERIAL (PARTIAL)

ITEM	PART NAME	STANDARD	LOW TEMPERATURE	ALLOY CARBON STEEL	STAINLESS STEEL
1	BODY	ASTM A216 WCB	ASTM A352 LCC	ASTM A217 WC6	ASTM A351 CF8M
2	PLUG	ASTM A216 WCB	ASTM A351 CF8	ASTM A351 CF8	ASTM A351 CF8M
3	ARTICULATED JOINT	ASTM A276 410	ASTM A276 304	ASTM A276 304	ASTM A276 316
4	STEM	ASTM A276 410	ASTM A276 304	ASTM A276 304	ASTM A276 316
5◆	GEAR	ASSEMBLY			
6	SCREW	ASTM A193 B7 / B7M	ASTM A320 L7 / L7M	ASTM A193 B7 / B7M	ASTM A193 B8M
7	GLAND FLANGE	CARBON STEEL	ASTM A350 LF2	ASTM A182 F11	ASTM A276 316
8	PACKING	GRAPHITE / PTFE			
9	O-RING	VITON	VITON	VITON	VITON
10	THRUST WASHER	RPTFE	RPTFE	RPTFE	RPTFE
11	INJECTION FITTING	CARBON STEEL	STAINLESS STEEL	STAINLESS STEEL	SS316
12	CHECK VALVE	CARBON STEEL	STAINLESS STEEL	STAINLESS STEEL	SS316
13	COVER	ASTM A216 WCB	ASTM A352 LCC	ASTM A217 WC6	ASTM A351 CF8M
14	METAL DIAPHRAGM	SS304 / SS316			
15	COVER BOLT	ASTM A193 B7 / B7M	ASTM A320 L7 / L7M	ASTM A193 B16	ASTM A193 B8M
16	COVER NUT	ASTM A194 2H / 2HM	ASTM A194 7M	ASTM A194 4	ASTM A194 8M
17	REGULATING BLOCK	ASTM A276 410	ASTM A276 304	ASTM A276 304	ASTM A276 316
18	ADJ. BOLT	ASTM A193 B7 / B7M	ASTM A320 L7 / L7M	ASTM A320 L7 / L7M	STAINLESS STEEL
19	GASKET	SS304 / SS316+GRAPHITE			

◆ ELECTRICAL OPERATOR, PNEUMATIC OPERATOR, HYDRAULIC OPERATOR ETC. ARE AVAILABLE

NOTE: OTHER MATERIALS ARE AVAILABLE UPON REQUEST.

PRESSURE BALANCE LUBRICATED PLUG VALVE

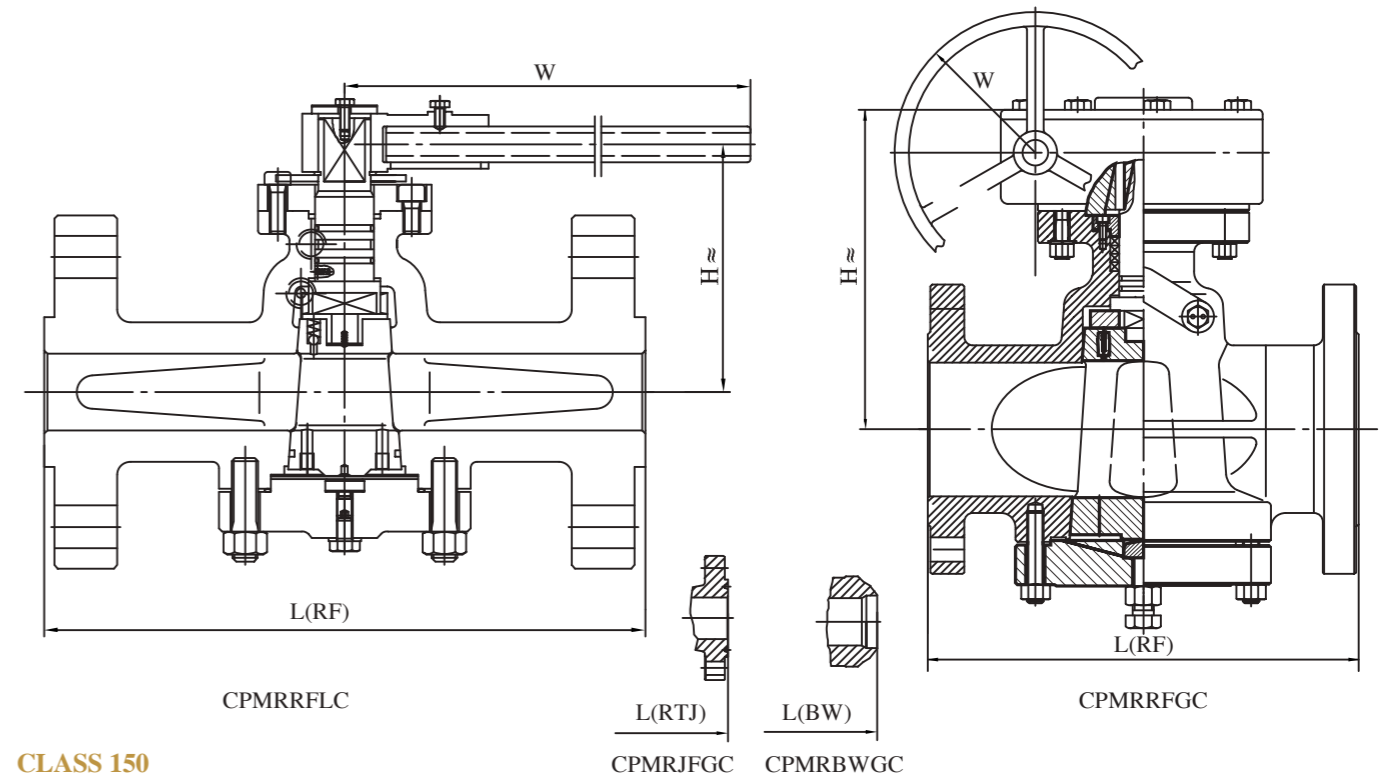

CLASS 150

NPS	in	2	2-1/2	3	4	6	8	10	12	14	16	18	20	24	26	28	30	32	36
DN	mm	50	65	80	100	150	200	250	300	350	400	450	500	600	650	700	750	800	900
L(RF)	mm	178	191	203	229	267	292	533	610	686	762	864	914	1067	1245	1346	1397	1524	1727
L(BW)	mm	267	305	330	356	457	521	559	635	686	762	864	914	1067	1245	1346	1397	1524	1727
L(RTJ)	mm	191	203	216	241	279	305	546	622	699	775	876	927	1080	1270	1372	1422	1553	1756
H	mm	140	168	190	220	278	300	320	380	415	460	500	580	650	-	-	-	-	-
W	mm	400	450	550	200	200	350	350	350	350	350	350	600	800	-	-	-	-	-
WT(RF)	Kg	18	24	33	54	90	150	210	275	372	520	786	1006	1708	-	-	-	-	-

CLASS 300

NPS	in	2	2-1/2	3	4	6	8	10	12	14	16	18	20	24	26	28	30	32	36
DN	mm	50	65	80	100	150	200	250	300	350	400	450	500	600	650	700	750	800	900
L(RF)	mm	216	241	283	305	403	419	457	502	762	838	914	991	1143	1245	1346	1397	1524	1727
L(BW)	mm	267	305	330	356	457	521	559	635	762	838	914	991	1143	1245	1346	1397	1524	1727
L(RTJ)	mm	232	257	298	321	419	435	473	518	778	854	930	1010	1165	1270	1372	1422	1553	1756
H	mm	210	228	240	270	285	315	355	380	420	460	540	585	650	-	-	-	-	-
W	mm	470	550	620	300	350	350	350	350	350	350	600	600	800	-	-	-	-	-
WT(RF)	Kg	20	27	36	58	120	195	275	355	514	670	920	1253	2088	-	-	-	-	-

GEAR OPERATOR FOR ≥ NPS 4

PRESSURE BALANCE LUBRICATED PLUG VALVE

CLASS 600

NPS	in	2	2-1/2	3	4	6	8	10	12	14	16	18	20	24	26	30	32	36
DN	mm	50	65	80	100	150	200	250	300	350	400	450	500	600	650	750	800	900
L(RF)	mm	292	330	356	432	559	660	787	838	889	991	1092	1194	1397	1448	1651	1778	2083
L(BW)	mm	292	330	356	432	559	660	787	838	889	991	1092	1194	1397	1448	1651	1778	2083
L(RTJ)	mm	295	333	359	435	562	664	791	841	892	994	1095	1200	1407	1461	1664	1794	2099
H	mm	210	225	243	273	325	335	395	435	475	510	570	610	740	-	-	-	-
W	mm	580	580	630	350	350	705	450	500	500	600	800	800	600	-	-	-	-
WT(RF)	Kg	22	32	43	75	143	345	354	575	730	1135	1466	2055	3600	-	-	-	-

CLASS 900

NPS	in	2	2-1/2	3	4	6	8	10	12	14	16	18	20	24
DN	mm	50	65	80	100	150	200	250	300	350	400	450	500	600
L(RF)	mm	368	419	381	457	610	737	838	965	1029	1130	1219	1321	1549
L(BW)	mm	368	419	381	457	610	737	838	965	1029	1130	1219	1321	1549
L(RTJ)	mm	371	422	384	460	613	740	841	968	1038	1140	1232	1334	1568
H	mm	240	250	260	287	370	420	470	520	585	610	650	678	780
W	mm	1000	1000	1000	350	350	350	350	600	800	800	800	600	600
WT(RF)	Kg	45	52	36	130	256	455	750	1050	1356	1690	2655	3875	6816

CLASS 1500

NPS	in	2	2-1/2	3	4	6	8	10	12	14	16	18	20	24
DN	mm	50	65	80	100	150	200	250	300	350	400	450	500	600
L(RF)	mm	368	419	470	546	705	832	991	1130	1257	1384	1537	1664	1943
L(BW)	mm	368	419	470	546	705	832	991	1130	1257	1384	1537	1664	1943
L(RTJ)	mm	371	422	473	549	711	841	1000	1146	1276	1407	1559	1686	1972
H	mm	253	255	270	338	416	468	520	595	630	675	738	765	860
W	mm	1000	1000	350	350	350	350	350	600	800	800	600	600	600
WT(RF)	Kg	57	78	100	180	425	734	1165	1889	2800	4042	5410	7236	12000

CLASS 600-CLASS 900-GEAR OPERATOR FOR ≥ NPS 4"

CLASS 1500-GEAR OPERATOR FOR ≥ NPS 3"

PRESSURE BALANCE LUBRICATED PLUG VALVE

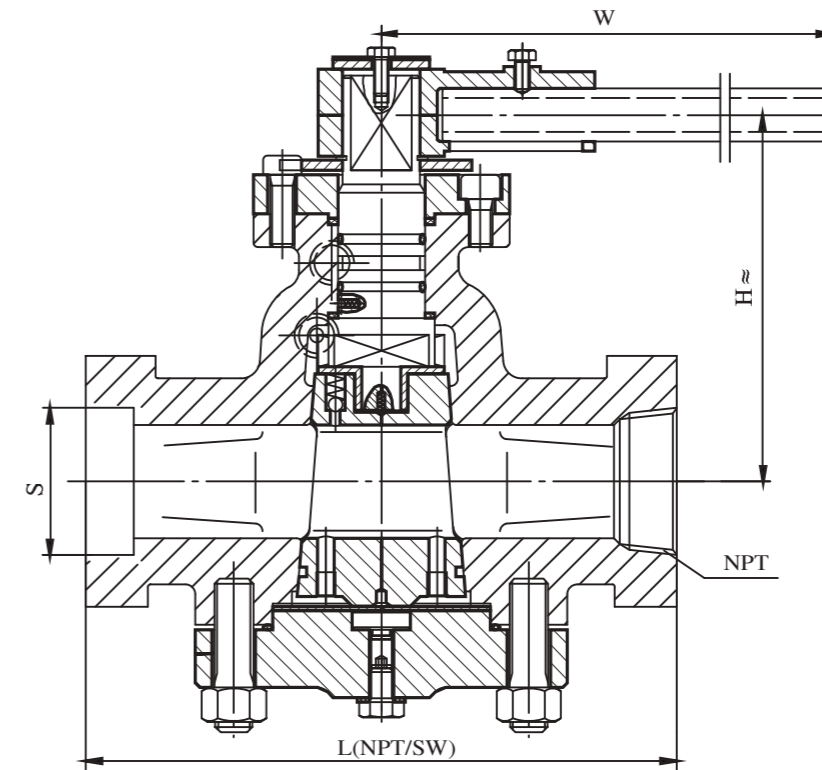

CPMRNTLC
CPMRSWLC

CLASS 150-CLASS 1500

NPS	in	1/2	3/4	1	1-1/2	2
DN	mm	15	20	25	40	50
L(NPT)	mm	89	133	133	229	229
L(SW)	mm	89	133	133	229	229
NPT	in	1/2	3/4	1	1-1/2	2
S	mm	21.8	27.1	33.8	48.7	61.1
H	mm	110	135	135	190	190
W	mm	70	80	120	120	180
WT(NPT)	Kg	3	8	20	38	45

INSTALLATION, MAINTENANCE AND OPERATING INSTRUCTIONS PLUG VALVE

NPS		150Lb	300Lb	600Lb	900Lb	1500Lb
IN	mm	N.m				
2"	50	100	170	290	415	655
3"	80	118	219	380	542	865
4"	100	300	535	918	1259	2065
6"	150	626	1080	1815	2550	4023
8"	200	2030	3205	5115	7020	10850
10"	250	2165	3259	6090	8518	13388
12"	300	3120	5200	8595	11988	18795
14"	350	4845	8485	14405	20325	-
16"	400	6030	10695	18245	-	-
18"	450	9145	15940	27000	-	-
20"	500	12020	21040	35975	-	-
24"	600	19425	34480	58965	-	-

THE STATIC STRESS ANALYSIS

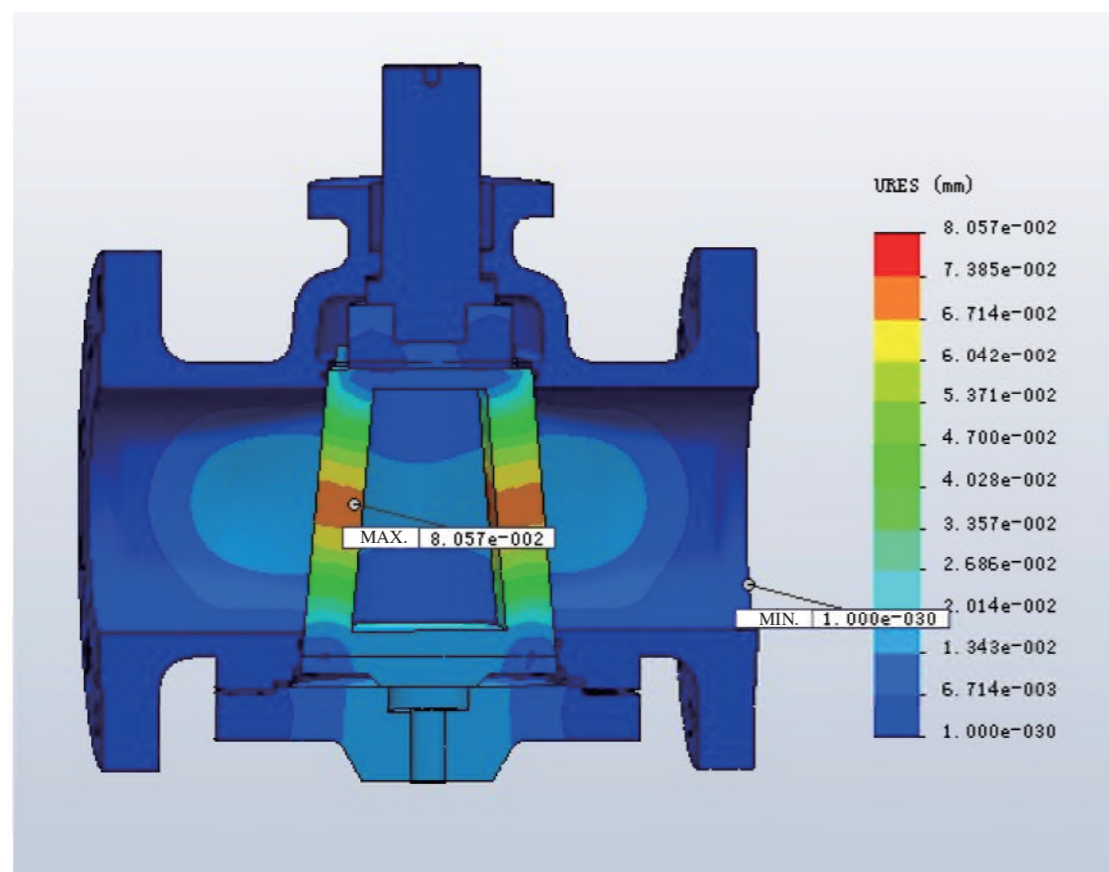

1. STORAGE

- 1.1. Valves must be stored in a dry and ventilative room and placed orderly. the stem can't bear any strength .
- 1.2. During the period of storage, the valve should be always on and inlet and outlet should be blocked .
- 1.3. During the period of storage, the outside portion of the stem and the machined surface should be covered by an easily cleaned antirust.

2. VALVE INSTALLATION

- 2.1. The valve can be installed freely, but it should be convenient to maintenance, inspection and operation.
- 2.2. Before installation, operators must review whether the contents on the marking and nameplate conform with the practical requirements.
- 2.3. Before installation, operators must clean the internal chamber and inspect whether studs between the body and the bonnet are fastened symmetrically and packings are dropped tightly symmetrically and the stem is bearing strength.
- 2.4. The flowing direction of the media is not restricted.
- 2.5. Mustn't take the worm gear box as the lifting eye to use.
- 2.6. After installation, valves must be blown and tested by the system pressure.
- 2.7. The practical condition intending to use valves must conform with the requirements specified on nameplate and in the operation instruction.
- 2.8. The valve only works for getting or shutting off media. Mustn't take it as the regulation valve.
- 2.9. The plug is turned through the handwheel. Mustn't use any other assistant levers or drives to operate the valve.
- 2.10. During the period of using valves, the following projects must be inspected at an expected time. Once any noncompliance is found, please correct it right now.
 - a. Whether fasteners become less crowded or not.
 - b. Whether packing is worn out and gaskets are mangled or not. (inspection without work)
 - c. Whether the actuator is flexible and there is the phenomena that valves can't turned.
 - d. Whether the seal surface are mangled or worn out. (inspection without work).
 - e. Whether leakage takes place at the cooperating position of the seat and the body or not. (inspection without work)
 - f. Whether the wallthickness of valves becomes thin distinctly for corrosion or erosion or not. If the wallthickness is less than the net valuation only satisfying the requirements of tensile strength or there exists a visually leakage, the valve must be scraped.
- 2.11. After valves are inspected and assembled, they are tested per responsible specifications and the records must be documented to refer to later.

3. VALVE MAINTENANCE

Faults	Reasons	Eliminating ways
There exist some leakages between the plug and the seat.	1.The fastening strength in advance is not enough. 2.The seal ring is torn or dirty. 3.The seal ring is deformed or invalid.	1. Add strength in advance. 2. Repair over again or skive the seal surface and clean the dirt. 3. Renew the seal ring.
There are some leakages in the cooperating position of the seat and the body.	The seat is damaged.	Renew the seat.
Leakages take place in the stem packing.	1. The dropping strength to packing is not adequate. 2. The packing invalid for a long time.	1. Regulate the bolt and nut over again. 2. Renew the packing.
Leakages happen in connecting position of the body and the bonnet.	1. The stud fastening the body and the bonnet become less crowded. 2. The gasket is damaged.	1. Equally fasten nuts over again. 2. Renew the gasket.



KASKO DEMİRÇELİK MAKİNE VE İNŞAAT SANAYİ TİCARET LİMİTED ŞİRKETİ

**Güzelyurt Mah. Mehmet Akif Ersoy Cad. No: 38 Gökdemir Plaza Kat: 3 Ofis: 24 Zip Code:
34524 Esenyurt / İSTANBUL**

Tel: +90 850 441 25 67

Cell: +90 541 699 01 34

info@kaskomakine.com

kaskomakine.com