

TABLE OF CONTENTS

PAGE

A History of Growth and Excellence / Market and Customers	2
Production Cycle	3
Table of Contents / General Features	4
Introduction to Products	5
Pressure Seal / Stem Seal	6
Forging x Casting for Valves	7
Flexible Wedge and Parallel Slides Wedge	8
Over-pressurization, Pressure Locking and Thermal Binding in Gate Valves: Problems and Solutions	9-11
Gate Valves	12
Materials and Features	12
Dimensions and Weights	13
"T"-Type Globe and Stop-Check Valves	14
Materials and Features	14
Dimensions and Weights	15
"Y"-Type Globe and Stop-Check Valves	16
Materials and Features	16
Dimensions and Weights	17
"T" Piston Check Valves	18
Materials and Features / Dimensions and Weights	18
"Y" Piston Check Valves	19
Materials and Features / Dimensions and Weights	19
Tilting Disc Check Valves	20
Materials and Features / Dimensions and Weights	20
Swing Type Check Valves	21
Materials and Features / Dimensions and Weights	21
Actuators and Accessories	22
How to Specify and Figure Number	23

GENERAL FEATURES

ORIGIN OF THE TECHNOLOGY

We have been manufacturing Pressure Seal Valves for more than 35 years and during 10 years under license of the world's largest manufacturer of pressure seal valves.

The Pressure Seal (PS) system uses the process pressure to exercise additional force in the body/bonnet sealing ring, ensuring far superior sealing of this area. The sealing rings are metallic, thus avoiding the possibility of wear or deterioration. The thrust ring above the sealing rings ensures homogeneous distribution of forces in the entire circumference.

CHOOSING VALVE TYPE

Choose the valve type according to the application (gate, globe or check):

Gate valves allow choosing the type of wedge.

Globe, Globe non return stop-check and Check piston valves allow choosing the body construction ("T" or "Y").

Check valves allow choosing the design: Piston, Swing or Tilting Disc.

SIZE

The valve size must be in accordance with the existing or designed pipe size. Check valves must take into consideration the flow rate for a perfect operation.

The valves must follow the Pressure Class determined by ASME B16.34, that make a relation between Pressure Class (Standard or special) and design Pressure, design temperature and body material.

MATERIALS

The chosen materials must be compatible with the application and among others, must be considered the fluid, the pressure and the temperature. In case of doubt, contact our specialists.

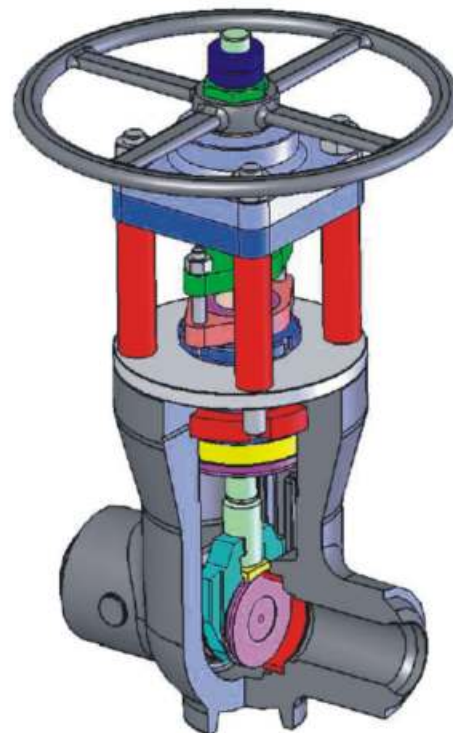

GATE VALVES

Gate valves are typically used in on-off services, in applications where no pressure loss and excellent two-directional sealing are required. They are not recommended for control. The ideal operating conditions are fully opened or fully closed. Their use in the intermediate positions (for control) may damage the seat, body and wedge sealing surfaces. Gate valves are usually installed in horizontal piping, with the stem in the vertical position upwards. They may be installed with the stem in another position provided that the manufacturer has been previously noticed at the time of the order, since this implies in design changes and, consequently, in the manufacturing process.

After the closing of the gate valve with the torque required for sealing, the valve must be relieved with 1/8 to 1/4 turn of the stem so as to avoid unnecessary stress in the stem resulting from thermal expansion. Such relief does not imply loss of sealing.

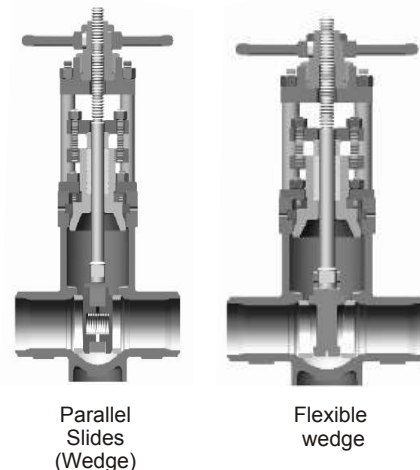

GLOBE AND GLOBE STOP-CHECK VALVES

Globe valves are used to control flow and/or block lines, usually installed with the flow direction entering under the disc. The globe valves supplied by -VICE are available with construction option in "T", "Y" and Angular (90°). Because of the constructive geometry, the "T" globe valves have pressure loss higher than the "Y" valves. "T" valves are economically superior, due to the smaller weight and easier actuation. Globe valves with angular construction 90° are installed replacing elbows in the piping, saving space. Standard globe valves are designed for control and blocking, however, they are not recommended to be used in control applications for a long period with an opening less than 20%, since it may cause damage to the internal components.

Globe Stop-check valves must be installed with stem in the vertical position and the flow direction under the plug. When the stem is opened, the fluid pressure under the plug opens the valve, allowing the fluid to pass. When the stem is in the closed position, has sealing capacity in both flow directions. With the stem in the open position, they operate as a piston-type (check) valve. In the closed position, the plug is pushed against the sealing seat by the stem, blocking the flow in the piping, such as in globe valve. Such kind of valve is normally applied in the replacement of two valves, a block valve (gate or globe) and a swing type check valve. The most common applications are in the discharge of pumps or in the protection against reverse flow of equipment connected to a common collector, such as boilers, pumps, etc.

Globe and Globe stop-check valves are usually operated by Handwheel. Are also available with gear reducer and handwheel, electric actuator or pneumatic or hydraulic cylinder.

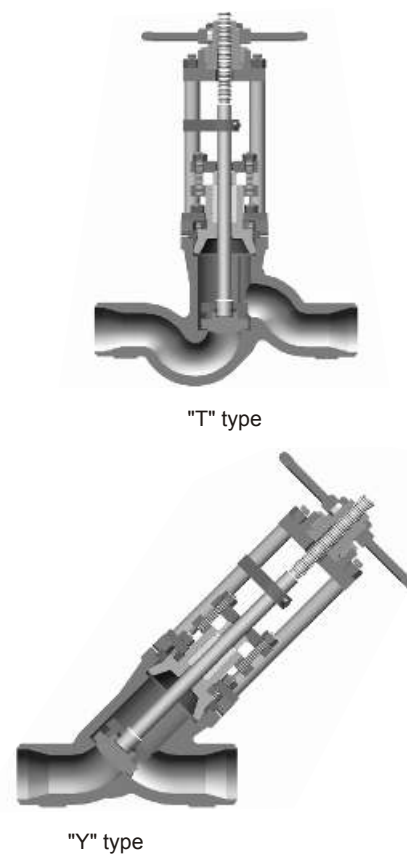

CHECK VALVES

Check valves are used to prevent flow reversion in piping. They may be applied in the horizontal or vertical position (only upward flow). Swing-type check valves have low loss of pressure and must be applied preferably when the flow speed is moderate. It is very important the correct sizing of this valve type. Very low or very high flow speeds cause damage to the internal components and shorten valve life. Applications involving large number of cycles with quick reversion of the flow direction, turbulent flows or pulsating flows must also be avoided.

Contact for advice in the selection of the proper product for your application.

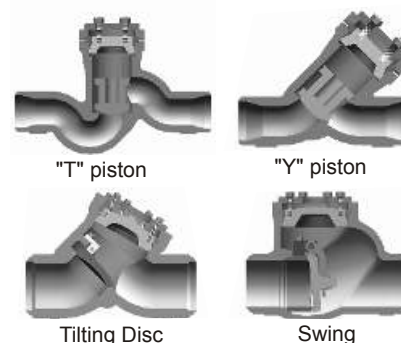

Pressure Seal, Standard or Live-Loaded design

- The Thrust Ring Absorbs the Force promoted by Internal Pressure;
- Spacer Ring has the right clearance to avoid Gasket deformation or extrusion through it;
- Gasket is made from graphite or silver coated soft steel (to prevent corrosion and galling). It provides the surface for adequate sealing.
- Belleville Springs are responsible for the live-loaded design (Optional). Live-loading stores energy for automatic compensation of bonnet movement during transient loads (pressure or temperature) while keeping an upward force in the bonnet assuring sealing.

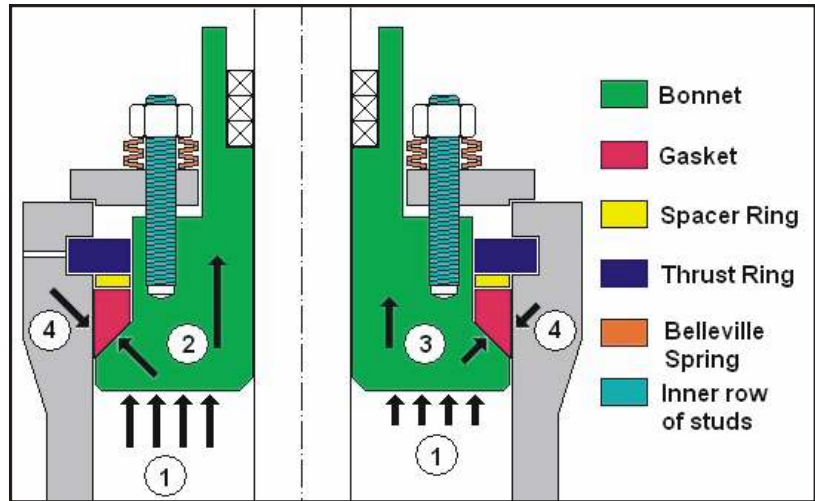

1. Internal Pressure;
2. Higher the internal pressure, higher the sealing force;
3. If the internal pressure decreases, the sealing force decreases too;
4. Sealing force according to internal pressure.

Stem Seal, Standard or Live-Loaded Design

1. **Backseat.** cone-in-cone design eliminates problems with over-torque;
2. **Leak-off for double packing (optional).** A lantern ring and a leak-off pipe are provided to remove any leakage from the lower packing set;
3. **Heavy two-piece gland.**
4. **Live-loading (optional).** Belleville springs assure a permanent load on the packing, even after a long time without maintenance.
5. **For Globe Valves to lower operation torque when compared to rotating stem.** The torque arm prevents stem rotation, indicates the position and actuates the limit switches.
6. **The non-rotating stem** close roundness, stringent tolerances and superior surface finish, as well as packing chamber superior surface finish, assure effective sealing.
7. **Pre-compressed rings.** Each braided graphite ring is preformed and compressed at installation to ensure extreme tightness and high packing strain.

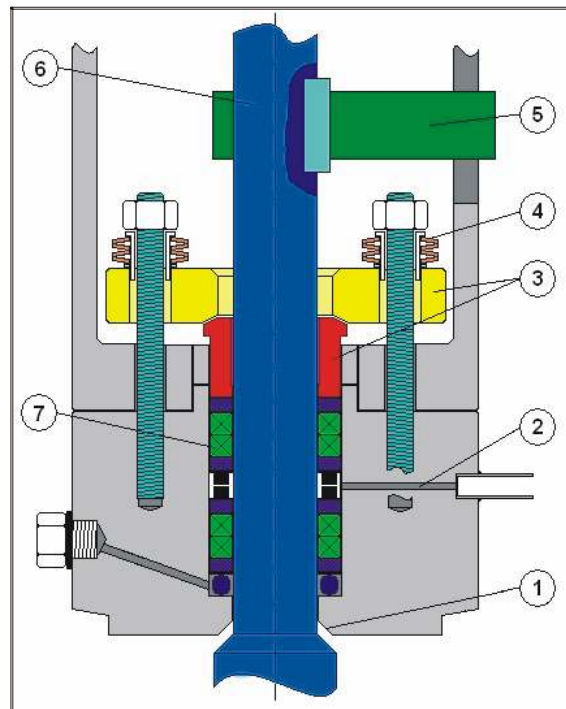

3 Solutions

3.1 Solutions for Over-Pressurization and Pressure Locking

Once determined that Over-Pressurization and/or Pressure Locking is a potential problem, the solution is to provide a pressure relief device for the valve body cavity. Below, some ways that this can be done:

3.1.1 Equalizing Pipe or One Side Wedge Hole

The equalizing pipe connects one side of the valve to the valve body cavity. **The valve will only seal in one direction**; this means that the equalizing pipe must be on the high pressure side when the valve is closed.

A second way to connect the high pressure side to the valve body cavity is provided by making a hole in one side of the wedge. The same way as the equalizing pipe, **the valve will only seal in one direction**.

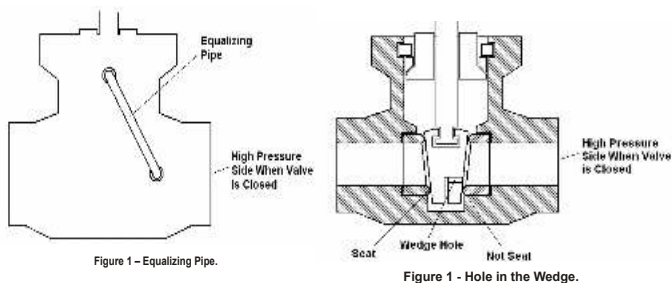

3.1.2 Equalizing Pipe with Valve

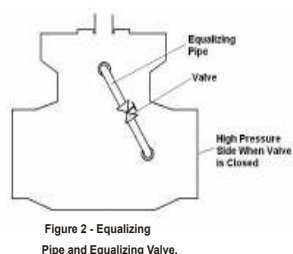

The valve can seal from both sides. **Note that the pressure relief is not available when the valve in the equalizing pipe is closed. Equalization only happens when high pressure is on the side B and the valve in the equalizing pipe is opened.** This means that when the high pressure is on side A, equalization will not happen.

3.1.3 Relief Valve

A valve connecting the valve body cavity to the atmosphere is another way to provide pressure relief. A self actuated valve or a drain valve can be used as seen in the pictures below. The discharge of this valve must be made to a safe location.

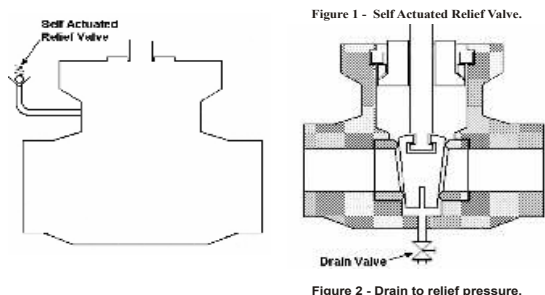

3.1.4 Self-Actuating Equalizing Device (SAED) When High Pressure can Occur on Both Sides

SAED is a special device that provides a solution for Over-Pressurization and Pressure Locking while allowing valve to seal in both directions automatically and self-operated. This means that there is no need for manual actuation or the use of external hardware in the valve for pressure equalization. The way this device works is described below:

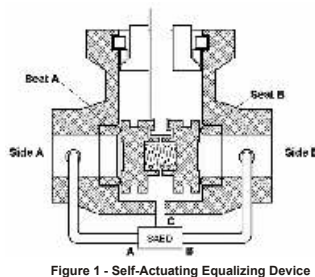

Port **A** is connected to one valve side;
 Port **B** is connected to the other valve side;
 Port **C** is connected to the valve body cavity

High Pressure on the A Port side (Figure 9):

- The shuttle is pushed to seat on the low pressure side.
- The pressure is then equalized between the high pressure side **A**, and the valve cavity **C**.

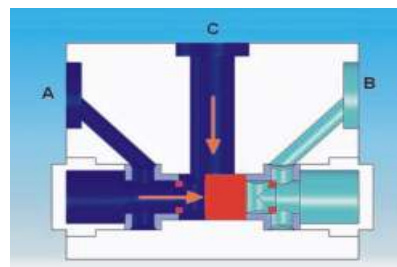

- Any high pressure on the **C** Port side (valve body cavity) will escape to Port **A**, preventing over pressure in the valve body cavity.

Reverse Pressure (Figure 10):

- The shuttle is pushed to seat on the low pressure side.
- The pressure is then equalized between the side **B** and the body cavity **C**.

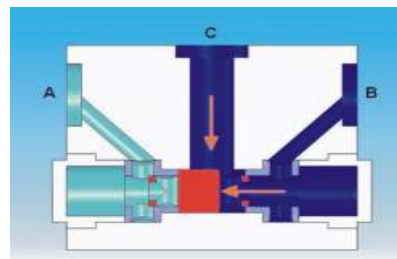

- Any high Pressure on the C Port side (valve body cavity) will escape to Port **B**, preventing over pressure in the valve body cavity.

THREADED BUSHING - Bronze material, supported by bearing, when applicable, to minimize the torque.

STEM - In Heat-treated stainless steel, with fine finishing, to reduce friction with the packing.

PRESSURE SEAL - Simplified and Pressure-aided the body/bonnet sealing.

SEAT RINGS - Coated with Stellite and welded to the body, do not obstruct the flow of fluid.

BODY - Straight flow. Minimizes the pressure loss.

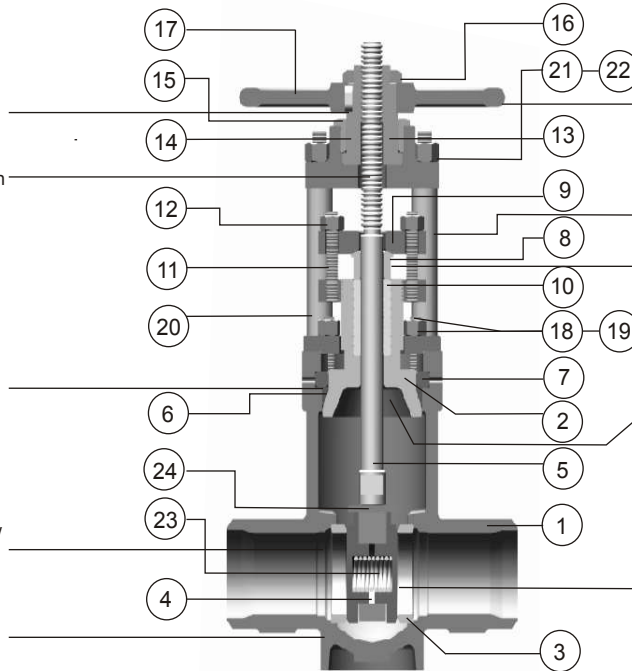

ACTUATOR - May be supplied With handwheel, gear reducer, electromechanical, pneumatic or hydraulic actuator.

YOKE - Simplified and tubular, make easier the maintenance and replacement of actuators.

PACKING GLAND, HUB and FLANGE - Manufactured in two self-aligning pieces, recessed in the gland flange eliminates frequent re-tightening.

BACKSEAT - Hardened and contained in the bonnet.

WEDGE - Flexible, Solid or Parallel: discs with springs and stroke limits by position decrease the cost of automation.

MATERIALS ACCORDING TO ASME B16.34

Pos.	Description	WC B	WC 6	WC 9	C12A	C F 8 M
1.	Body ¹⁾	ASTM A 216 GR WCB	ASTM A 217 GR WC6	ASTM A 217 GR WC9	ASTM A 217 GR C12A	ASTM A 351 GR CF8M
2.	Bonnet ¹⁾	ASTM A 216 GR WCB	ASTM A 217 GR WC6	ASTM A 217 GR WC9	ASTM A 217 GR C12A	ASTM A 351 GR CF8M
3.	Seat ring ²⁾	ASTM A 216 GR WCB	ASTM A 217 GR WC6	ASTM A 217 GR WC9	ASTM A 217 GR C12A	ASTM A 351 GR CF8M
4.	Wedge ²⁾	ASTM A 216 GR WCB	ASTM A 217 GR WC6	ASTM A 217 GR WC9	ASTM A 217 GR C12A	ASTM A 351 GR CF8M
5.	Stem ³⁾	AISI 410	AISI 410	AISI 410	AISI 410	AISI 316
6.	Sealing ring	LOW CARBON STEEL SILVER PLATED	LOW CARBON STEEL SILVER PLATED	LOW CARBON STEEL SILVER PLATED	STAINLESS STEEL SILVER PLATED	STAINLESS STEEL SILVER PLATED
7.	Segmented ring	ALLOY STEEL	ALLOY STEEL	ALLOY STEEL	ALLOY STEEL	ALLOY STEEL
8.	Gland hub	AISI 410	AISI 410	AISI 410	AISI 410	AISI 316
9.	Gland plate	CARBON STEEL	CARBON STEEL	CARBON STEEL	CARBON STEEL	CARBON STEEL
10.	Packing	CARBON FIBER	CARBON FIBER	CARBON FIBER	CARBON FIBER	TEFLON
11.	Gland studs	CARBON STEEL	CARBON STEEL	CARBON STEEL	CARBON STEEL	CARBON STEEL
12.	Gland nut	CARBON STEEL	CARBON STEEL	CARBON STEEL	CARBON STEEL	CARBON STEEL
13.	Bushing bearing ⁴⁾	CARBON STEEL	CARBON STEEL	CARBON STEEL	CARBON STEEL	CARBON STEEL
14.	Threaded bushing	ASTM B 584 ALLOY 863	ASTM B 584 ALLOY 863	ASTM B 584 ALLOY 863	ASTM B 584 ALLOY 863	ASTM B 584 ALLOY 863
15.	Safety sleeve	CARBON STEEL	CARBON STEEL	CARBON STEEL	CARBON STEEL	CARBON STEEL
16.	Handwheel nut	CARBON STEEL	CARBON STEEL	CARBON STEEL	CARBON STEEL	CARBON STEEL
17.	Handwheel	ASTM A 395	ASTM A 395	ASTM A 395	ASTM A 395	ASTM A 395
18.	Bonnet stud	ASTM A 193 GR B7	ASTM A 193 GR B7	ASTM A 193 GR B7	ASTM A 193 GR B7	ASTM A 193 GR B7
19.	Bonnet nut	ASTM A 194 GR 2H	ASTM A 194 GR 2H	ASTM A 194 GR 2H	ASTM A 194 GR 2H	ASTM A 194 GR 2H
20.	Tubular yoke	CARBON STEEL	CARBON STEEL	CARBON STEEL	CARBON STEEL	CARBON STEEL
21.	Yoke stud	ASTM A 193 GR B7	ASTM A 193 GR B7	ASTM A 193 GR B7	ASTM A 193 GR B7	ASTM A 193 GR B7
22.	Yoke nut	ASTM A 194 GR 2H	ASTM A 194 GR 2H	ASTM A 194 GR 2H	ASTM A 194 GR 2H	ASTM A 194 GR 2H
23.	Spring ⁵⁾	STAINLESS STEEL	STAINLESS STEEL	STAINLESS STEEL	STAINLESS STEEL	STAINLESS STEEL
24.	Pin ⁵⁾	STAINLESS STEEL	STAINLESS STEEL	STAINLESS STEEL	STAINLESS STEEL	STAINLESS STEEL

"T" - TYPE GLOBE VALVES, SIZES ½" TO 14" CLASSES 900#, 1500# AND 2500#

Class	Dimensions (mm)													
	Sizes (inches)	*1/2"	*3/4"	*1"	*1.1/2"	*2"	2.1/2"	3"	4"	6"	8"	10"	12"	14"
900#	L	--	--	254	305	368	254	305	356	508	660	787	914	991
	L (FR)	--	--	254	305	368	419	381	457	610	737	838	965	1029
	L (FRTJ)	--	--	254	305	371	422	384	460	613	740	841	968	1039
	~H	--	--	325	460	494	593	767	674	874	1005	1535	1680	1596
	ØV	--	--	203	280	280	406	500	500	580	580	750	750	750
	Weight (kg) BW	--	--	14,7	30	70	70	70	130	360	576	950	1400	1960
1500#	L	216	229	254	305	216	254	305	406	559	711	864	991	1067
	L (FR)	216	229	254	305	368	419	470	546	705	832	991	1130	1257
	L (FRTJ)	216	229	254	305	371	422	473	549	711	842	1001	1146	1276
	~H	262	262	325	460	494	593	674	794	974	1394	1474	2005	2005
	ØV	220	220	203	280	280	406	500	580	580	750	945	1200	1200
	Weight (kg) BW	11,1	11,1	14,7	30	80	80	120	220	520	1024	1620	2680	3200
2500#	L	264	273	308	384	279	330	368	457	610	762	914	1041	--
	L (FR)	264	273	308	384	451	508	578	673	914	1022	1270	1422	--
	L (FRTJ)	264	273	308	387	454	514	584	683	927	1038	1292	1444	--
	~H	262	262	262	482	482	495	603	850	971	1200	1416	1524	--
	ØV	220	220	220	350	350	406	500	500	750	750	945	1200	--
	Weight (kg) BW	11,1	11,1	14,7	37	120	120	205	270	790	1280	2250	3400	--

Notes:

1. Face-to-face dimensions (mm), according to ASME B16.10, when applicable, Weights in (kg).
2. Pressure classes according to ASME B16.34 "standard or special"
3. Valves with size above 3" are supplied with impact handwheel.
4. For BW connection, please inform the piping schedule.
5. Dimensions, weights and other information of this catalogue are subject to changes.

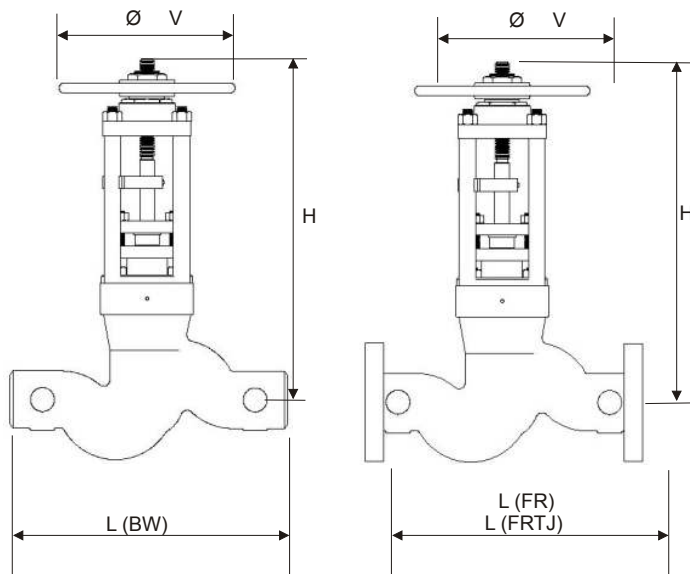

Figure	Class
7750	900#
7850	1500#
7950	2500#

VALVE ACTUATOR SIZING

The procedure for selecting an actuator is to calculate the required torque and thrust to operate the valve at the required service conditions. A safety margin of actuator capability is always allowed for the final actuator selection, but oversized actuators are avoided.

Because of the wide variations in system operating conditions, actuator sizing is based on the following:

ACTUATOR TYPE	LINE PRESSURE	DIFFERENTIAL PRESSURE (CLOSED)	POWER SUPPLY
ELECTRIC	Specified by customer	Specified by customer	Voltage, type, phase and frequency specified by customer
PNEUMATIC	Specified by customer	Specified by customer	Air pressure specified by customer
HYDRAULIC	Specified by customer	Specified by customer	Hydraulic pressure specified by customer
HANDWHEEL/ GEAR ACTUATED	70% of CWP unless otherwise advised by customer	70% of CWP unless otherwise advised by customer	200 lb (90 kg) rimpull unless otherwise specified by customer

GEAR ACTUATORS

MODEL	CLASS	OPTIONAL	STANDARD
PS Gate Flexibles Wedge	600	4 - 6"	8" & up
	900	4 - 6"	8" & up
	1500	4"	6" & up
	2500	-	6" & up
	4500	-	6" & up
PS Globe T Pattern	600	-	6" & up
	900	-	6" & up
	1500	-	6" & up
	2500	-	6" & up
PS Parallel Slides Wedge	600	4 - 8"	10" & up
	900	4 - 6"	8" & up
	1500	4 - 6"	8" & up
	2500	6"	8" & up
PS Globe Y-Pattern	900	-	6" & up
	1500	-	6" & up
	2500	-	6" & up

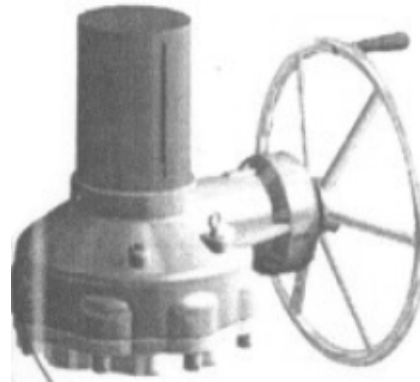

STANDARDIZED YOKE AND GEAR REDUCERS

The yoke of 's valves are standardized and allow more flexibility in the assembling of the actuators. Valves with handwheel may be converted in field into gear reducer or electromechanical actuator with a minimum of new parts.

ELECTRIC AND CYLINDER ACTUATORS

Information required for:

CYLINDER (PNEUMATIC OR HIDRAULIC)

1. Valve size, figure number or description.
2. Operating conditions (pressure, temperature, flow rate and fluid).
3. Maximum differential (shut-off) pressure.
4. Primary power supply-air or hydraulic-available maximum and minimum pressure and source.
5. Failure mode (open, closed, as is)
6. Control voltage and enclosure designations (NEMA, etc.).
7. Auxiliary equipment:
 - a) limit switches,
 - b) solenoids
 - c) positioner
 - d) manual over-ride
8. Valve orientation.
9. Preference for specific manufacturer, if any.

ELECTRIC

1. Valve size, figure number or description.
2. Valve operating conditions (pressure, temperature, flow rate and fluid).
3. Maximum differential (shut-off) pressure.
4. Primary power supply:
 - a) electric-voltage, phase cycles,
5. Control voltage.
6. Valve stem position.
7. Closing time and frequency.
8. Required construction (NEMA, etc.) or local environment.
- 9 - Auxiliary equipment:
 - a) push-button stations,
 - b) reversing controllers,
 - c) position indicators,
 - d) other (i.e., stem covers, etc.),
 - e) Positioner.
10. Special requirements (i.e., radiation, seismic, etc).
11. Preference for specific manufacturer, if any.

BY PASSES

IN ACCORDANCE WITH MSS-SP45 GATE (2½ -24") AND GLOBE (2½ - 24") CLASSES 600-2500

Main Valve Nominal Pipe Size In	By-Pass Nominal Pipe Size	
	Séries A ⁽¹⁾	Séries B ⁽²⁾
2½ e 3	½	½
4	½	1
5 e 6	¾	1¼
8	¾	1½
10	1	1½
12 e 14	1	2
16, 18 e 20	1	3
24	1	4

(1) Series A includes steam service for warming up before the main line is opened, and for balancing pressures where the lines are of limited volume.
 (2) Series B includes steam lines conveying gases or liquids where bypassing may facilitate the operation of the main valve through balancing the pressure on both sides of the disc (or discs).

OTHERS:

• SEAL WELDED BODY/BONNET (LIP SEAL)

This construction provides extra assurance against leaks in the body/bonnet joint. A metallic ring is placed between the body and the bonnet and sealed with welding in its whole circumference.

• LIMIT SWITCHES

• INTERLOCKS

• LEAK OFF (¼ NPT)

• FLOOR STANDS



KASKO DEMİRÇELİK MAKİNE VE İNŞAAT SANAYİ TİCARET LİMİTED ŞİRKETİ

**Güzelyurt Mah. Mehmet Akif Ersoy Cad. No: 38 Gökdemir Plaza Kat: 3 Ofis: 24 Zip Code:
34524 Esenyurt / İSTANBUL**

Tel: +90 850 441 25 67

Cell: +90 541 699 01 34

info@kaskomakine.com

kaskomakine.com