



Step 0 Type/Structure/Features

Please refer to this for type, structure and features of each products.

Step 1 Selection

Search the suitable product from ID-chart by application. Details are on the products page.

Step 2 Sizing

Confirm the note for selecting steam trap such as safety factor to obtain the proper traps.

Step 3 Attentions for usage

Please check some guidelines for optimal usage of Steam Trap.

Reference material Steam trap materials

What is Steam? This materials are described the purposes of usage on each steam traps helping to energy savings activities.

Types of Traps

What is trap?

A general term for self-acting valves which automatically discharge condensate from equipment or pipes

What is condensate (drain)?

- Water generated by condensation of steam in steam system
- Oil and/or water generated in pneumatic line

What is steam trap?

Trap used for steam equipment or steam pipes

Mechanical type

Actuates by the specific gravity difference between steam and condensate.



TSF-10

Thermodynamics type

Actuates by the thermodynamic characteristics of steam and condensate.



TD-10NA

TD-30NA

Thermostatic type

Actuates by the temperature difference between steam and condensate.



TS-7



Float Type Steam Trap TSF Series

High durability

Excellent in durability thanks to important parts such as valve, seat, air vent and float in stainless steel material.

Air vent

Incorporated thermostatic air vent discharges air inside the piping and shortens warming-up time.

Strainer

Built-in strainer helps high resistance to scale.

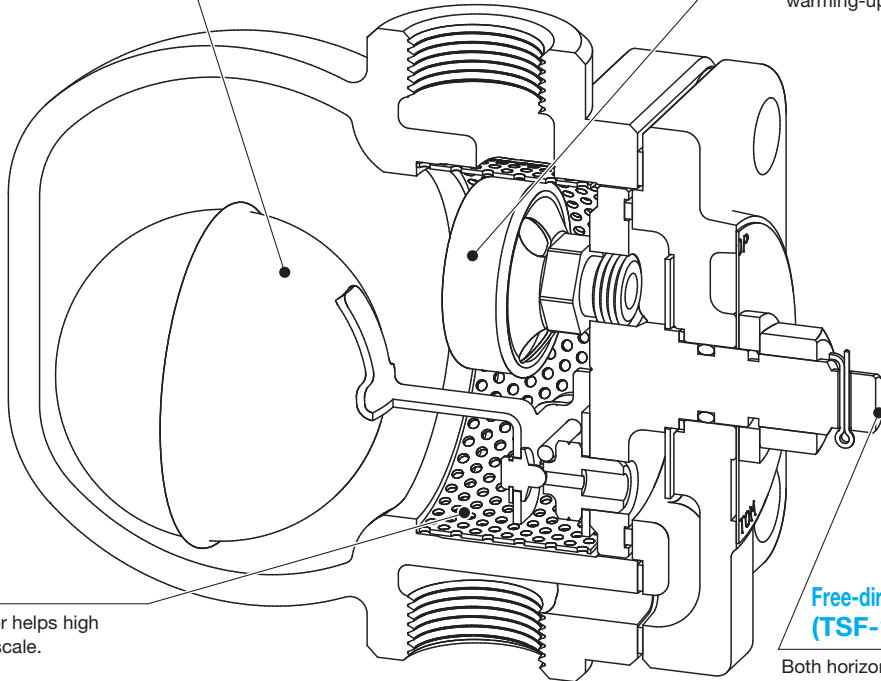

Free-direction installation (TSF-10/11 series)

Both horizontal and vertical installation is possible thanks to rotating cock. Flow direction can be switched easily without disassembly.

• Installation posture

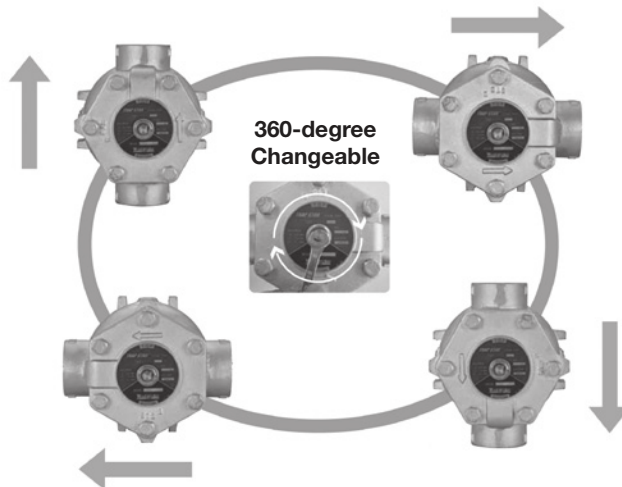

Bucket Type Steam Trap TB-20/TB-20F

5
Steam Trap

High reliability and long life

All internal parts are made of stainless steel.

Water seal

The valve seat will be always sealed by condensate, which prevents steam from being discharged.

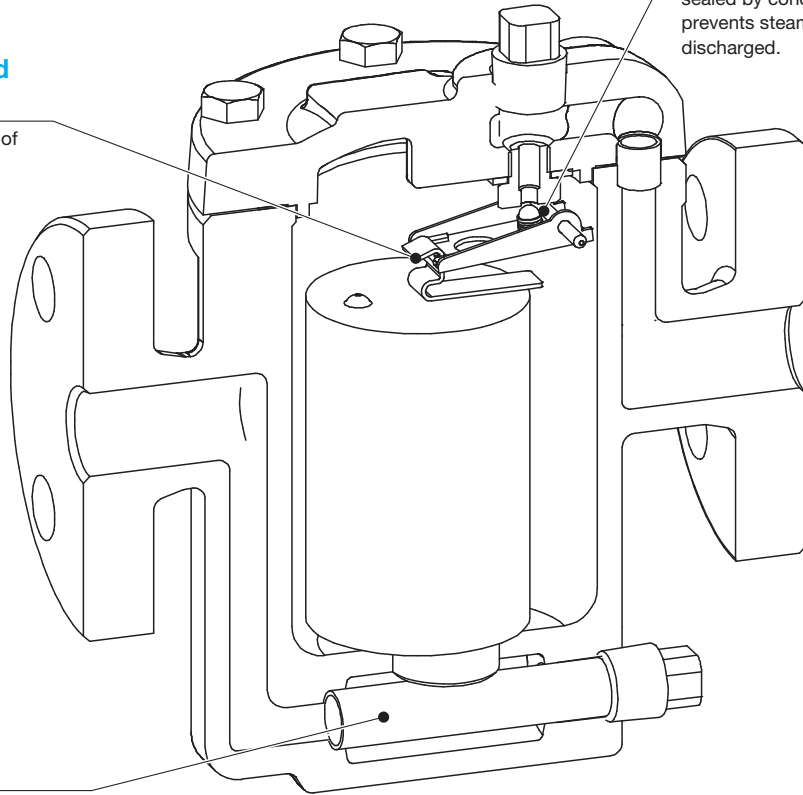

Strainer

Scale-resistant thanks to self-contained strainer.

Water hammer resistance

High resistance to water hammer, as the bucket is open and there are no sealed parts.



TB-20

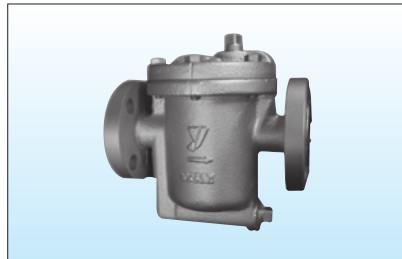

TB-20F

Bellows Type Steam Trap TS-7

TS-7/8 bellows type steam trap meets wide range of requirement as a thermostatic (bellows) type steam trap with by-pass function.

Hexagonal cover (switching part)

4 functions of "STOP", "BY-PASS", "TRAP", and "TEST" can be switched easily by spanner or monkey wrench.

Strainer

Equipped with built-in strainer.

By-pass valve

Built-in by-pass function allows reducing the cost for piping and construction remarkably. New design of by-pass valve has enabled to more compact body.

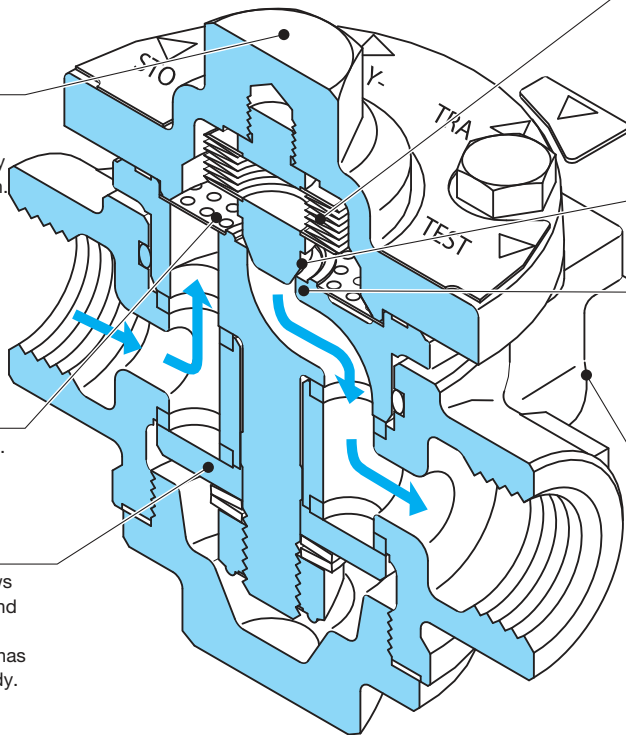

Bellows

TS-7/8 can be used in wide range of pressure thanks to welded bellows. The trap operates at the temperature 12degC lower than saturation point, and does not leak live steam.

Valve

Cock (Valve seat)

Cock and valve seat are made of stainless steel and integrated into one part.

Outlet screwed 3/8 for test

Operation of trap can be checked without effect of back pressure. (With "TEST" mode)



TS-7

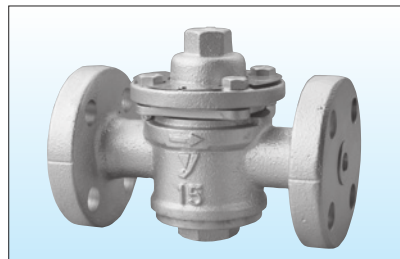

TS-8



Disc Type Steam Trap TSD-42

TSD-42 is disc type steam trap for high pressure (maximum pressure: 4.2 MPa). It is compact and lightweight, and can be installed horizontally or vertically.

5
Steam Trap

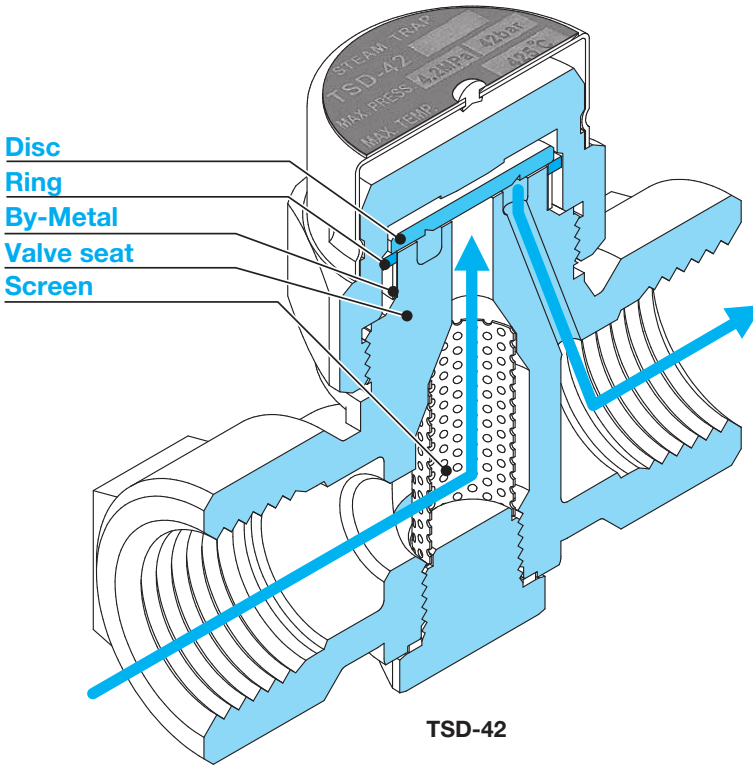

Stable operation by air insulation

- It prevents no-load operation or steam leakage caused by influence of outside temperature.

Excellent durability

- Disc and valve seat has superior durability thanks to stainless steel material processed by special heat treatment.

Shortened warming up time

- By-Metal helps shortening warming up of steam equipment by solving air-binding and efficiently discharging cold water and air at startup.



TSD-42



TD-10NA

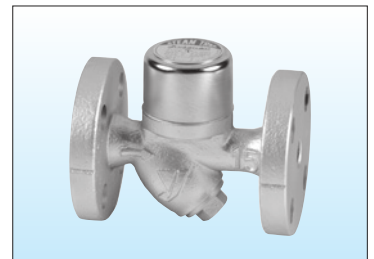

TD-30NA

Selection of Steam Trap

	Mechanical Trap		Thermodynamic Trap	Thermostatic Trap
	Float	Bucket	Disc	Bellows
Operating principle	Difference in specific gravity between steam and condensate (up-and down movement due to buoyancy)		Difference in thermodynamic properties between steam and condensate	Difference in temperature between steam and condensate (Closed at steam temperature and opens at lower temperature)
Operating characteristics	Continuous	Intermittent	Intermittent	Continuous
Condensate accumulation	None	None	Possible	Possible
Steam loss amount	Negligible	Negligible	Small	Negligible
Discharge of air	Excellent	Fair	Excellent	Excellent
Water hammer proof	Fair	Excellent	Excellent	Poor
Back pressure tolerance	Excellent	Excellent	Poor (P_2 must be 50% of P_1 or less)	Fair
Response to load fluctuation	Immediate	Fair	Delayed	Delayed
Scale proof	Fair	Excellent	Poor	Fair
Size and weight	Large and heavy	Large and heavy	Small and light	Small and light
Installation posture	Limited*	Limited	Unlimited	Unlimited
Operation during failure (in many cases)	Closed	Open	Open	Closed
Application example	<ul style="list-style-type: none"> · Steam header, drain separator · Jacketed kettle · Plate heat exchanger requiring large condensate discharge and quick air-venting 	<ul style="list-style-type: none"> · Steam header · Steam main pipe · Main pipe end where noise of water hammer must be avoided 	<ul style="list-style-type: none"> · Steam main pipe end · ON-OFF controlled coil heater in boiling tank which has water hammer 	<ul style="list-style-type: none"> · Heat exchanger without water hammer · Air conditioning unit with limited installation space

* TSF-10/11 series are adjustable in flow direction.

Guidelines for Selection

How to decide the type of steam trap

When selecting steam trap, it is recommended to select the most suitable operation type according to desired application. Pick up 3 or 4 important items from the selection points (on the previous page) according to purpose, usage and type of machine where steam trap will be installed, and select the most suitable operation type.

<Example>

1. Accumulation of condensate
None: Float / Inverted Bucket
Possible: Disc / Bellows
2. Tolerance to back pressure
Excellent: Float / Inverted Bucket
Fair: Bellows
Poor: Disc (back pressure must be 50% of inlet pressure or less)
3. Discharge of air
Excellent: Float / Disc / Bellows
Fair: Inverted Bucket
4. Response to load fluctuation
Immediate: Float
Fair: Inverted Bucket
Delayed: Disc, Bellows

How to decide

If there is an indispensable point, put the top priority on it. Usually, please select 1st and 2nd choice from the most satisfactory operation type of trap.

Type of trap	Float	Bucket	Disc	Bellows
Condensate accumulation	None	None	Possible	Possible
Back pressure tolerance	Excellent	Excellent	Poor	Fair
Discharge of air	Excellent	Fair	Excellent	Excellent
Response to load fluctuation	Immediate	Fair	Delayed	Delayed

1st choice: Float
2nd choice: Inverted Bucket

Original guideline

We recommend making an original guideline on your company's own according to the process above and your experience.

No	Application	Condensate amount	Max. working pressure	Differential pressure	Safety factor	Required capacity	1st choice	2nd choice



Sizing of Steam Trap

After selecting certain type of steam trap, it is also necessary to select the optimal model and size of the trap. Followings are items to be considered when sizing the trap.

1. Condensate amount

· Check the amount of condensate for each steam usage, based on past result or calculation. Principle is that steam consumption equals to amount of generated condensate.

1) Steam header

· The function of steam header is to separate condensate contained in the steam supplied from boiler and provide dry steam to the process. When the system is running, the amount of the condensate generated at the header equals to the heat release from the header surface. Since most of the condensate in the steam header is carryover from the boiler, condensate amount can be estimated as below:

$$\text{Condensate amount} = \text{Boiler capacity} \times \text{carryover rate (normally 3-5\%)}$$

<Example: 4 boilers with capacity 1,000 kg/h each>
 $4 \times 1,000 \times 0.05 = 200 \text{ (kg/h)}$

Carryover rates are different among boilers. Consider safety factor (mentioned later) according to type of boiler.

2) Condensate amount (required steam amount) of steam main pipe

· Main pipe supplies steam to many lines and process equipment in the system. Therefore, accumulation of condensate and retention of air inside the steam main pipe will cause noise and shock of water hammer. This will badly damage equipment in the system as well as pipe itself.

a) Warming-up: Much condensate is generated until the pipe is warmed up to the steam temperature.

$$W = \frac{P_w \times c_p (TS - T_a)}{r}$$

- W : Condensate amount per pipe 1 m (kg/m)
- P_w: Weight of pipe 1 m (kg/m)
- c_p : Specific heat of pipe material (kJ/kg °C)
 Steel pipe: 0.483kJ/kg °C
 Copper pipe: 0.399kJ/ kg °C
- TS: Steam temperature (°C)
- T_a : Outside air temperature (°C)
- r : Latent heat of steam (kJ/kg)

<Example>

- Pipe size: 150A (Sch 40)
- Steam temperature: 174.5°C (Saturated steam)
- Pipe length: 200 m
- Outside air temperature: 10°C
- Steam pressure: 0.8 MPa
- Latent heat of steam: 2038 kJ/kg
- 150A (Sch 40) Weight 27.7.kg/m
- Specific heat of pipe material 0.483 kJ/kg°C

$$W = \frac{27.7 \times 0.483 \times (174.5 - 10)}{2038} = 1.08 \text{ kg/m}$$

Though the pipe length is 200 m, flange, valve and fittings should be also considered. Assuming 220 m (additional 10%), condensate amount is $W = 1.08 \times 220 = 238 \text{ kg}$

If the line is to be warmed up in 20 minutes, total condensate amount per hour is $238 \times 60/20 = 714 \text{ kg/h}$

Since steam main pipe should be trapped on every 30 to 50 m, assume 5 traps on this case (4 in the middle + 1 on the pipe end).

$$\frac{714}{5} \times 2 \text{ (Safety factor)} = 286 \text{ kg/h}$$

Thus each steam trap should have discharge capacity of 286 kg/h.

■ Pipe dimensions and weights

Nominal size		Outside diameter mm	Surface area m ² /m	Weight		
A	B			SGP kg/m	Sch40 kg/m	Sch80 kg/m
10	3/8	17.3	0.054	0.851	0.851	1.11
15	1/2	21.7	0.068	1.31	1.31	1.64
20	3/4	27.2	0.085	1.68	1.74	2.24
25	1	34.0	0.107	2.43	2.57	3.27
32	1-1/4	42.7	0.134	3.38	3.47	4.57
40	1-1/2	48.6	0.153	3.89	4.10	5.47
50	2	60.5	0.190	5.31	5.44	7.46
65	2-1/2	76.3	0.240	7.47	9.12	12.0
80	3	89.1	0.280	8.79	11.3	15.3
100	4	114.3	0.359	12.2	16.0	22.4
125	5	139.8	0.439	15.0	21.7	30.5
150	6	165.2	0.519	19.8	27.7	41.8
200	8	216.3	0.680	30.1	42.1	63.8
250	10	267.4	0.840	42.4	59.2	93.9
300	12	318.5	1.00	53.0	78.3	129
350	14	355.6	1.12	67.7	94.3	158
400	16	406.4	1.28	77.6	123	203
450	18	457.2	1.44	87.5	145	254
500	20	508.0	1.60	97.4	184	311



Sizing of Steam Trap

b) Stable operation:

· Since generation of condensate during stable operation is due to heat release, the amount of heat dissipation has to be estimated by following formula.

$$Q = \frac{TS - Ta}{r}$$

Q : Amount of heat dissipation per pipe 1 m, per hour (kJ/m h)

Ts : Steam temperature (°C)

Ta : Outside air temperature (°C)

R : Thermal resistance (m h °C/kJ)

$$R = \frac{1}{2\pi} \left(\frac{1}{\lambda} \ln \frac{D_2}{D_1} + \frac{2}{D_3 \alpha^s} \right)$$

λ : Thermal conductivity of insulating material (kJ/m h °C)

D₁: Outer diameter of steam pipe

D₂: Outer diameter of insulating material

D₃: Outer diameter of outer material

α^s: Coefficient of heat transfer of convection and radiation between outer material and outside air

■ Coefficient heat transfer from the surface of outer material

Gs-Ta	20	40	60	80	100
α ^s	10	10.5	11.5	12.3	13.3

Gs: Surface temperature of outer material (°C)

Ta : Outside air temperature (°C)

In case of outdoor application with wind, multiply α^s by following coefficient.

Wind speed (m/s)	1.0	2.0	3.0	4.0	5.0
Coefficient	1.50	1.70	1.85	2.00	2.20

<Example>

Pipe size : 200A (Sch 40) Outside air temperature : 5°C
 Pipe length : 250 m Latent heat of steam : 2038 kJ/kg
 Steam pressure : 0.8 MPa Outer diameter of pipe : 216.3 mm
 Steam temperature: 174.5°C Insulating material : Glasswool
 Specific heat of pipe material 0.483 kJ/kg°C

Thickness of insulating material: 50 mm Thickness of outer material: 0.5 mm

Assuming α^s is 10 and wind speed is 2 m/s, α^s = 10 × 1.70 = 17

$$R = \frac{1}{2\pi} \left(\frac{1}{0.1827} \ln \frac{316.3}{216.3} + \frac{2}{317.3 \times 17} \right) = 0.331 \text{ m h } ^\circ\text{C/kJ}$$

Therefore amount of heat dissipation is $Q = \frac{(174.5 - 5)}{0.331} = 512.0 \text{ kJ/m h}$

Amount of generated condensate per hour is $\frac{(512.0 \times 275)}{2038} = 69.1 \text{ kg/h}$

3) Condensate amount (required steam amount) of process equipment

· Calculate steam amount necessary for doing required heating of the heated object or material. When making hot water (or putting heated material into produced hot water), estimate the amount of heat and steam required to heat water itself. Besides, amount of required steam to heat vessel or equipment around the water as well based on their material and approximate weight, since they also have to be heated up.

$$Q = \frac{W \times cp (T_2 - T_1)}{r} \times \frac{60}{t}$$

Q : Required steam amount = condensate amount (kg/h)

W : Weight of heated material (kg)

cp: Specific heat of heated material (kJ/kg °C)

T₁ : Temperature of heated material before heating (°C)

T₂ : Target temperature of heated material (°C)

r : Latent heat of steam (kJ/kg)

t : Heating time (minute)

<Example>

Estimate condensate amount when heating 1,000 kg of water in a stainless steel tank (assume 2,000 kg) from 20°C to 80°C in 30 minutes using 0.2 MPa steam.

Conditions:

	Heated material	Water	Stainless steel
Weight (kg)		1,000	2,000
Specific heat (kJ/kg °C)		4.184	0.499
Initial temperature (°C)		20	20
Target temperature (°C)		80	133 (saturated steam temp.)
Heating time (min)		30	30
Steam latent heat (kJ/kg)		2163.2	2163.2

$$\text{Water: } Q = \frac{1,000 \times 4.184 (80 - 20)}{2163.2} \times \frac{60 \text{ min}}{30 \text{ min}} = 232.10 \text{ (kg/h)}$$

$$\text{Stainless steel: } Q = \frac{2,000 \times 0.499 (133 - 20)}{2163.2} \times \frac{60 \text{ min}}{30 \text{ min}} = 104.27 \text{ (kg/h)}$$

Therefore, estimated steam consumption (condensate amount) is 232.10 + 104.27 = 336.37 (kg/h)



2. Safety factor

· When considering condensate amount, safety factor has to be used in order to cover unexpected factors such as fluctuation of condensate amount, drop of the differential pressure and condensate remaining from the day before. A referential guide of safety factor for each usage is shown on table 1. If the condensate amount can be estimated as per the previous paragraph using worst conditions of pressure/material/weight, the safety factor can be the minimum value.

■ Trap usage and safety factor

Application	Safety factor
Steam header	2 to 3
Separator	2
Steam main lines & branch lines	1.5 to 2
Coils for boil tank/plating tank	1.5
Finned air heaters, jacketed kettles	2 to 3
Press machines, cylinder dryers	2 to 3
Large heat exchanger for producing hot water	2
Radiator (fan coil unit)	2
Air handling unit	2
Tracing line	1.5

3. Maximum pressure = Design pressure

· This is about pressure resistance of the trap. The trap has to be able to endure the maximum pressure of the steam system.

4. Differential pressure = Inlet pressure of the trap - back pressure from the condensate line

· The capacity of the steam trap depends on differential pressure; Decrease in differential pressure lowers discharge capacity of the trap. There are factors which affect differential pressure such as rising condensate line, change of steam load, operation of PRV or control valve etc., and the differential pressure sometimes fluctuates while the system is operating. If the trap is sized based on the capacity under the maximum differential pressure, it might not be enough under smaller differential pressure. The trap must (1) be able to operate under the maximum differential pressure, and (2) have enough discharge capacity at the working (minimum) differential pressure.

■ EXAMPLE

Conditions:

- Estimated condensate amount: 500 kg/h
- Inlet pressure: 0.7 – 0.9 MPa
- Back pressure of the condensate line: 0.1 – 0.2 MPa
- Usage: Separator (before PRV)
- Required discharge capacity: 500×2 (safety factor) = 1,000 (kg/h)
- Maximum differential pressure: 0.9 MPa (assuming the outlet pressure becomes atmospheric)
- Working differential pressure: 0.5 MPa

From conditions above, the trap must be able to operate under 0.9 MPa and have 1,050 kg/h of discharge capacity under differential pressure 0.5 MPa.

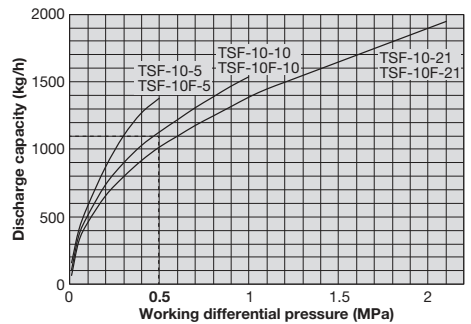

From this capacity chart, the capacity of TSF-10(F)-10 is around 1,100 kg/h, which can cover the conditions above.



Guidelines for Installing Steam Trap

· Be sure to install a steam trap at a place where maintenance and inspections can be implemented.

■ Fig. 1 Standard piping example of steam trap

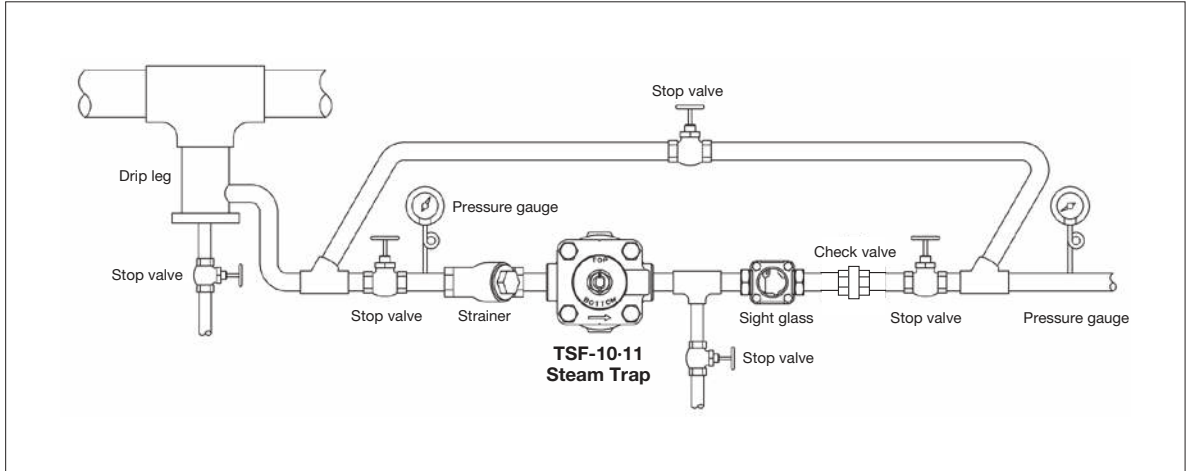

■ Fig. 2 Trapping of main steam piping

· Trapping at middle of piping

· Trapping at viser

· Trapping at pipe end

· Drip leg sizing

M	D	H ₁	H ₂	S
20A	20A	260	720	15A
25A	25A	260	720	15A
40A	40A	260	720	15A
50A	50A	260	720	20A
80A	80A	260	720	25A
100A	100A	260	720	25A
200A	100A	300	720	40A
250A	125A	380	720	50A

- H₁ (mm) for manual warmup
- H₂ (mm) for automatic warmup



Fig. 3 Trapping of branch steam pipe

Followings are guidelines for 2 cases, the distance from main pipe to automatic valve on branch pipe is 3 m or less, and more than 3 m.

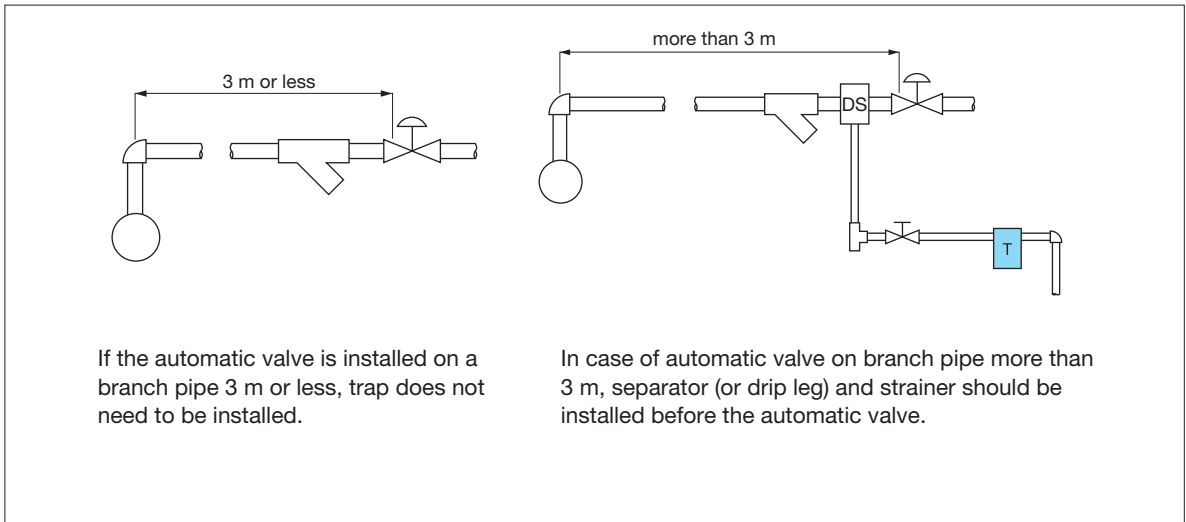

Energy saving, one of the most important universal issues must be realized by the effort of all of us. This guidebook presents operational principles and application examples of various types of steam traps, which are based upon our 70-year's experiences as a valve manufacturer. We believe that these information will help you select a proper model and save energy.

What is steam?

Steam is a transparent gas that has no color, no taste and no smell, and it generates when adding heat energy to water. Steam generates when you boil water by a kettle.

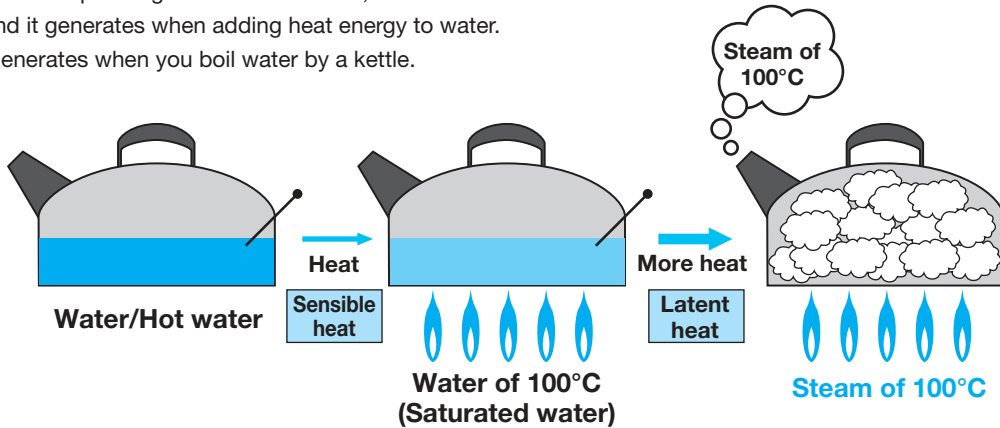

Steam generating mechanism

Cycle of steam generating

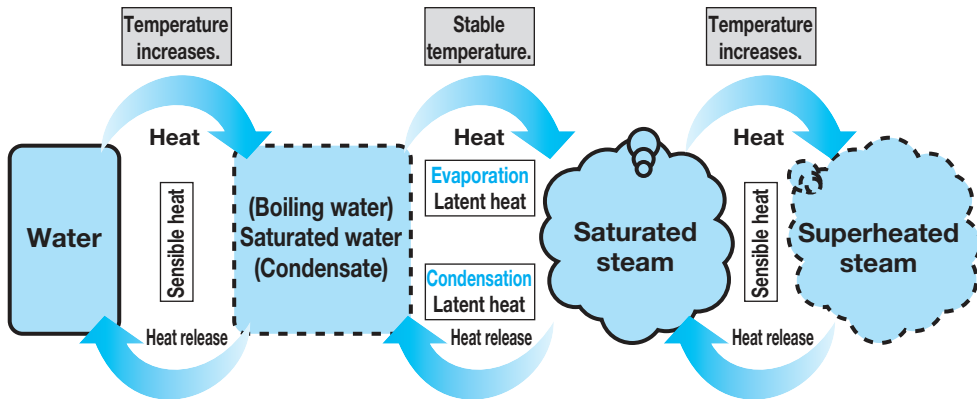

Cycle of Water and Steam

- ① Water temperature rises while heated under a stable pressure.
- ② When water is heated to the boiling point, the water temperature stops rising and it starts evaporation.
- ③ If the water is further heated, evaporation continues until all the water evaporates without temperature increase. This stable temperature is called “Saturated steam temperature” at which “saturated steam” exists under “saturated steam pressure.”
Steam is generally utilized as “saturated” condition. Quality of the saturated steam is expressed according to its water-containing ratio, as “saturated steam of ○○% dryness.”
- ④ When the saturated steam is further heated, the temperature begins to rise. This state of the steam is called “superheated steam.”
- ⑤ Superheated steam becomes saturated steam after heat release, and it finally condenses into water after further heat releasing.

The chart below shows the temperature change of 1 L (1 kg) of 0°C water while heated under the atmospheric pressure.

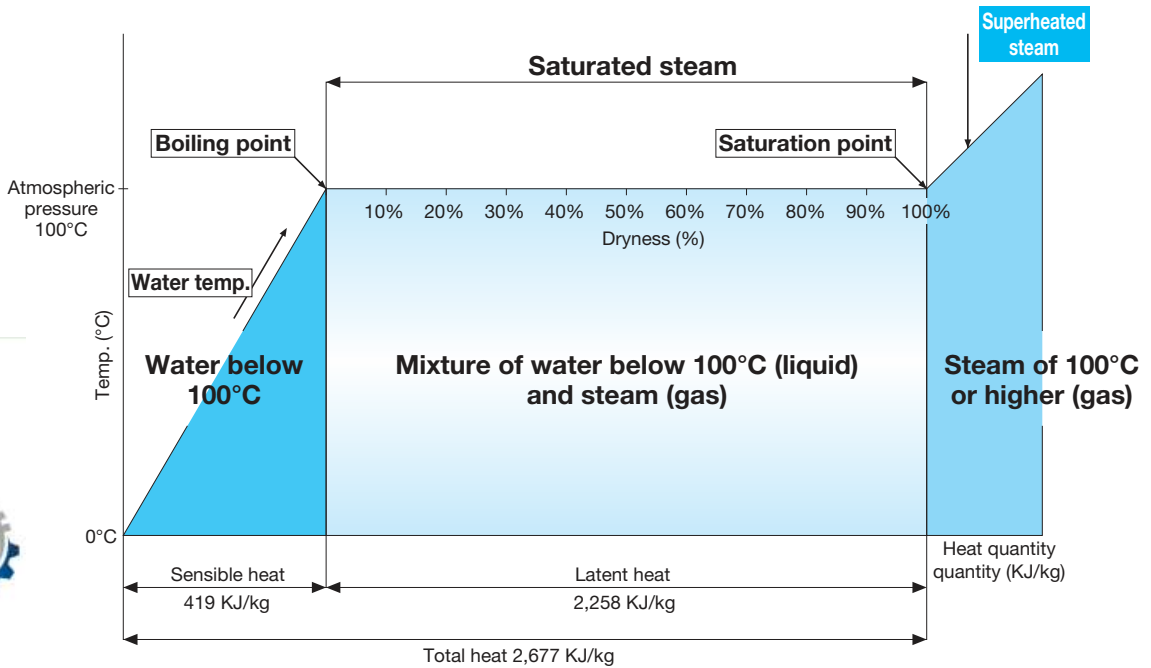

Change observed when 1 L (1 kg) of water is heated

The graph shows the change of water under the stable atmospheric pressure. Water begins boiling at 100 °C and the temperature stays stable until all the water evaporates. This means the saturated steam temperature is stable under a stable pressure, thus it can be utilized a stable heat source and its temperature can be controlled by its pressure.

The total heat required to heat and evaporate 1 L (1 kg) of water of 1°C can be shown as follows:

- Heat quantity required to heat water to its boiling point (sensible heat): 419 KJ/kg
 - Heat quantity required to heat boiling water until it complete evaporates (latent heat) 2,258 KJ/kg
- The total heat quantity is 2,677 KJ/kg (Sensible heat + Latent heat = Total heat quantity)

* Latent heat of saturated steam can be a useful heat source because of its large heat quantity.

■ Glossary

Boiling point: The temperature at which water starts boiling and changing into steam

Saturation point: The temperature at which all water (liquid) changes into steam (gas)

Dryness: Ratio of gas (steam) in the mixture of gas and liquid (saturated water)

Ex.) “97% of dryness” means that the steam contains 3% of saturated water.

Sensible heat: Amount of heat of hot water

→ Sensible heat can be sensed as temperature change.

Latent heat: Amount of heat that changes the state of material from liquid (hot water) to gas (steam)

→ Latent heat cannot be sensed as temperature change.

Total enthalpy: Summation of sensible heat and latent heat

Steam is a good heat source

Steam is one of the best heat sources because:

- Heating temperature can be controlled by controlling steam pressure.
- Material can be heated uniformly by utilizing latent heat.
- Material can be heated more effectively because steam provides latent heat which is larger than sensible heat.

Characteristics of steam

1. Pressure and temperature of saturated steam

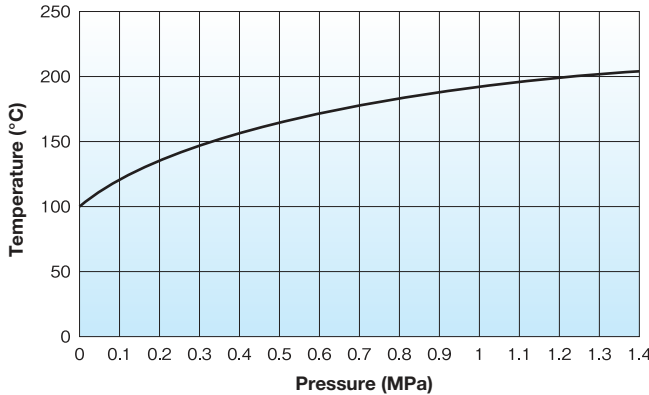

Saturated steam temperature rises as its pressure rises. Higher steam pressure is applied to get higher temperature.

2. Pressure and enthalpy of saturated steam

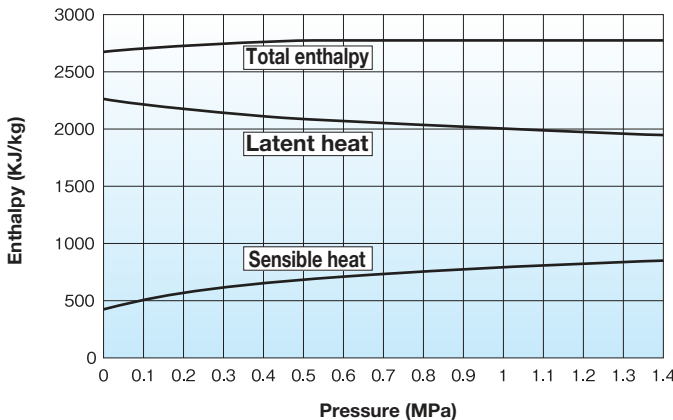

As the pressure rises, the enthalpy increases with rising sensible heat and falling latent heat. This means that the saturated steam of lower pressure has larger heat quantity.

3. Pressure and volume of saturated steam

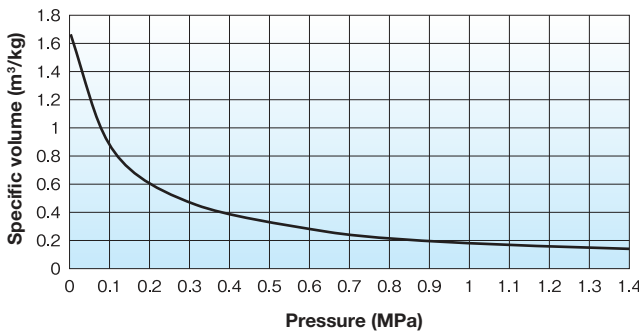

The specific volume of 1 kg of saturated steam drastically decreases as the pressure rises. This means that the saturated steam of higher pressure has smaller volume and can be applied to smaller diameter of piping.



■ Summary of saturated steam characteristics

Gauge pressure (MPa)	Temperature (°C)	Enthalpy (KJ/kg)		Total enthalpy	Specific volume (m ³ /kg)
		Sensible heat	Latent heat		
0.7	170	721	2,049	2,770	0.24
0.6	165	696	2,070	2,766	0.27
0.5	158	670	2,087	2,757	0.32
0.4	152	637	2,112	2,749	0.37
0.3	144	603	2,137	2,740	0.46
0.2	134	561	2,166	2,727	0.60
0.1	120	505	2,202	2,707	0.88
0.0	100	419	2,258	2,677	1.67



Saturated steam table

Reducing steam pressure causes decrease in temperature, sensible heat, and total enthalpy, while it also causes increase in latent heat and specific volume. Summarizing the steam characteristics, efficient steam utilization is suggested as below.

Tips for utilizing steam

Transfer at high pressure

... **Specific volume**

(Smaller specific volume realizes smaller-sized valve.)

Utilize at lower pressure

... **Latent heat**

(Steam of lower pressure has larger latent heat.)

Reduce pressure

... **Better dryness**

(Dryness improves as steam pressure lowers, because steam of lower pressure requires lower total enthalpy.)

■ Relationship between pressure and volume of saturated steam ... Example of application

Following shows the proper pipe sizing according to each required flow rate.

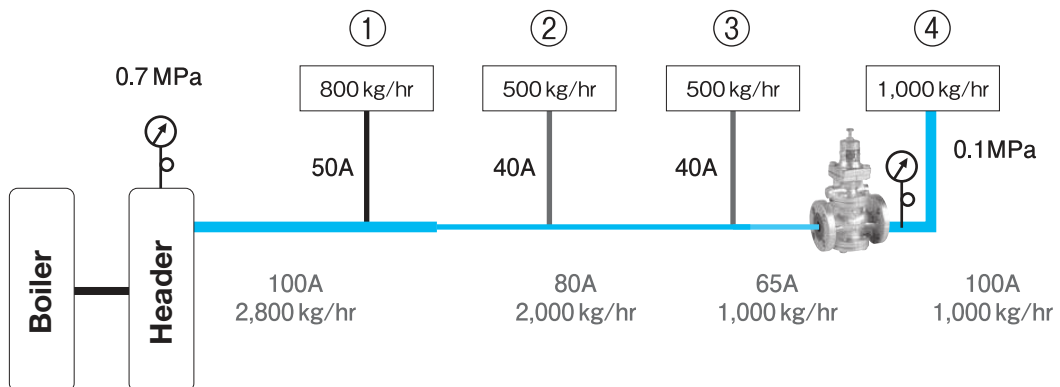

· Flow rate of saturated steam (at flow velocity of 30 m/s inside piping) kg/hr

	40A	50A	65A	80A	100A	150A	200A
0.7 MPa	577	933	1,537	2,172	3,697	8,032	13,972
0.1 MPa	163	263	433	612	1,042	2,264	3,938



Why you need steam trap

1. Elimination of condensate

Condensate is the by-product of heat transfer in a steam system. It forms in the distribution system due to unavoidable radiation. It also forms in heating and process equipment as a result of desirable heat transfer from the steam to the substance heated. Once the steam has condensed and given up its valuable latent heat, the hot condensate must be removed immediately. Although the available heat in condensate is negligible as compared to steam, condensate is still valuable hot water and should be returned to the boiler.

2. Elimination of air

Air is always present during equipment start-up and in the boiler feedwater. The steam velocity pushes the air to the walls of the heat exchangers, where they may block heat transfer. This compounds the condensate drainage problem, because the air must be removed along with the condensate.

3. Water hammer prevention

Condensate lying in the bottom of steam lines can be the cause of water hammer. Steam traveling at high speed makes “waves” as it passes over this condensate. If enough condensate forms, highspeed steam pushes it along, creating a dangerous slug that grows larger and larger as it picks up liquid in front of it. Anything that changes the direction-pipe fittings, regulating valves, tees, elbows, blind flanges-can be destroyed.

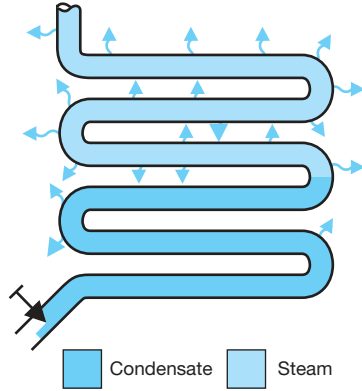

Coil half full of condensate can't work at full capacity.

How Water Hammer Occurs

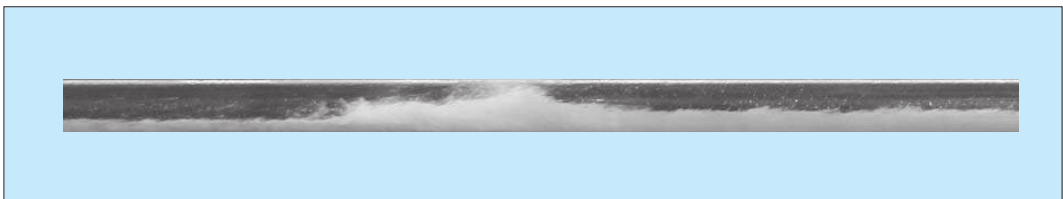
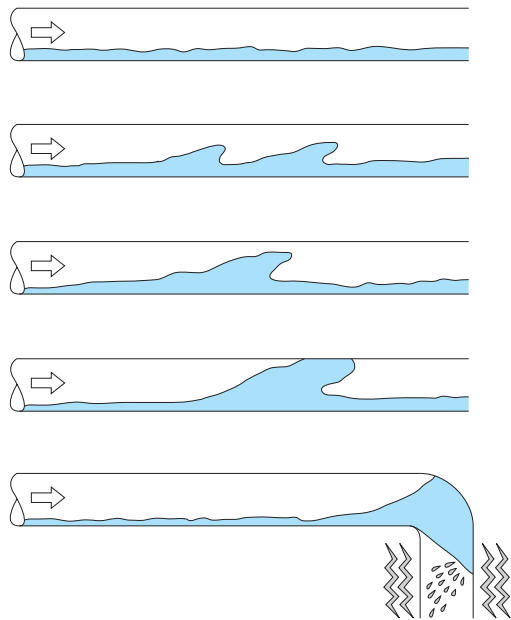

Picture of water hammer



TB-20,20F



- Bucket
- Float
- Disc
- Bellows
- Bimetal
- Wafer
- By-pass
- Stainless steel
- Connector
- Right to Left
- Down to Up
- Up to Down



TB-20



TB-20F

5
Steam Trap

■Features

1. Excellent durability ensured by unique internal structure (hemispherical valve, etc).
2. The upper plug is made of stainless steel, and is excellent in wear resistance.
3. Reliable performance due to all stainless steel made internal parts and the unique internal structure.
4. Super energy saving since intermittent operation removes air adiabatic wall in the heat exchanger and increases heat efficiency considerably.

■Specifications

Model		TB-20	TB-20F	
Nominal size		15A, 20A, 25A		
Connection		JIS Rc screwed	JIS 20K FF flanged	JIS 10K FF flanged
Application		Steam condensate		
Maximum pressure		2.0 MPa		1.0 MPa
Max. differential pressure	(A)	0.3 MPa		
	(B)	0.6 MPa		
	(C)	1.0 MPa		
	(D)	1.6 MPa	-	
Max. temperature		220°C		
Material	Body	Ductile cast iron		
	Valve	Stainless steel (heat treated)		
	Valve seat	Stainless steel (heat treated)		

· Available with ASME and EN flanged.

■Discharge Capacity Chart

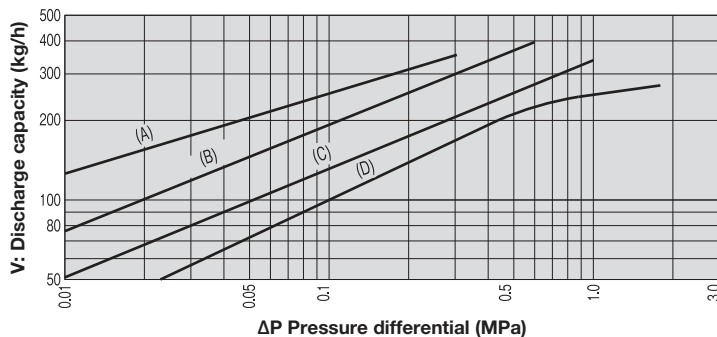

- The discharge capacity shown here is a continuous discharge capacity at the indicated differential pressure.
- In general, select a steam trap with a safety factor twice or threefold the regular level.



■ Dimensions (mm) and Weights (kg)

· TB-20

Nominal size	L	H	H ₁	A	Weight
15A	136	183	94	117	4.3
20A					
25A					

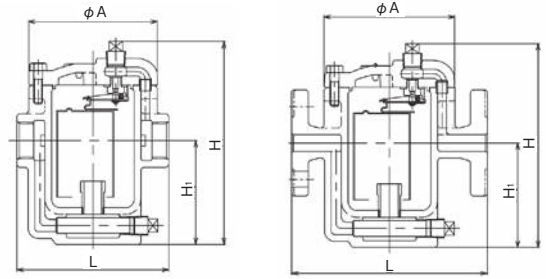

TB-20

TB-20F

· TB-20F

Nominal size	L	H	H ₁	A	Weight
15A	175	183	94	117	5.4
20A					6.0
25A					6.3

- The dimensions of the product with JIS 10K FF flanged and the product with JIS 20K FF flanged are identical.
- The thickness of JIS 10K FF flanges conforms to that of JIS 20K FF flanges.



■ Exploded View

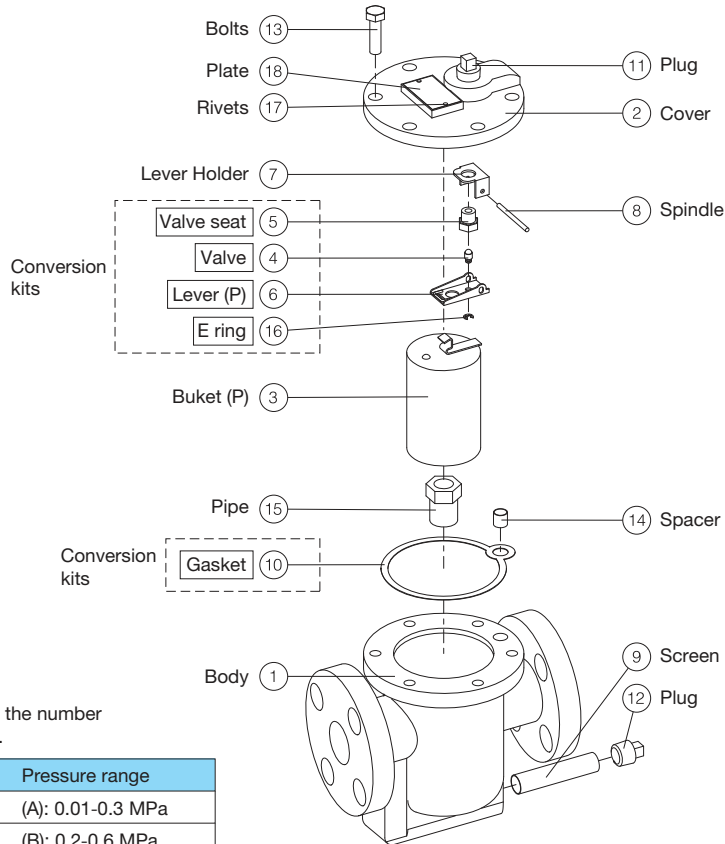

Refer to below table on the number of each conversion kits.

No.	Pressure range
K-93070	(A): 0.01-0.3 MPa
K-93071	(B): 0.2-0.6 MPa
K-93072	(C): 0.3-1.0 MPa
K-93073	(D): 0.6-1.6 MPa

* Part names shown in boxes are consumable items.

TB-5

Bucket	Float	Disc	Bellows
Bimetal	Wafer	By-pass	Stainless steel
Connector	Right to Left	Down to Up	Up to Down

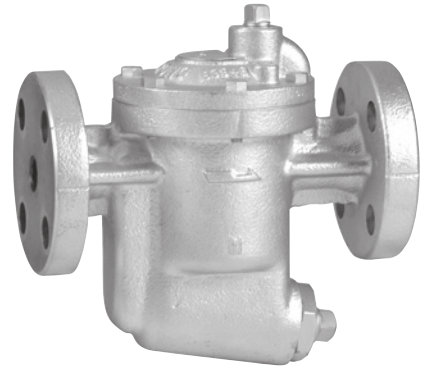

■Features

1. Excellent durability ensured by unique internal structure (free floating lever system, spherical valve, etc).
2. Reliable performance due to all stainless steel made internal parts and the unique internal structure.
3. Superior energy saving since intermittent operation removes air adiabatic wall in the head exchanger and increases heat efficiency considerably.
4. Distinguished scale resistance provided by built-in strainer and dual separation system.
5. Wide variety of options, including large vent and built-in type check valve.

■Specifications

Model		TB-5
Maximum pressure		1.0 MPa
Maximum working differential pressure		Refer to "Discharge Capacity Chart"
Max. temperature		220°C
Material	Body	Ductile cast iron
	Valve, valve seat	Stainless steel
	Bucket	Stainless steel
Connection		JIS 10K FF flanged
Nominal size		15A-50A

■Orifice Size

Max. working differential pressure MPa

	Nominal size	
	15A-25A	32A-50A
3/8 (9.5mm)	—	0.21
9/32 (7.1mm)	—	0.56
1/4 (6.4mm)	—	0.87
7/32 (5.6mm)	—	1.0
1/8 (3.2mm)	0.56	—
7/64 (2.8mm)	0.87	—
#38 (2.5mm)	1.0	—

■Discharge Capacity Chart

(The charts below show the discharge capacity of saturated condensate in actual operation.)

· 15A-25A

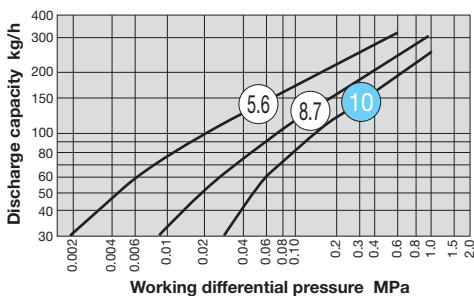

· 32A-50A

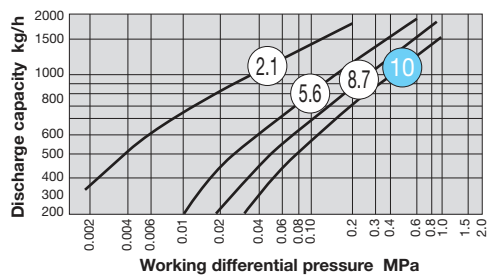

- The discharge capacity shown here is a continuous discharge capacity at the indicated differential pressure.
- In general, select a steam trap with a safety factor twice or threefold the regular level.
- The circled values are maximum working differential pressures (kgf/cm²). (The values in white circles represent a standard product, and those in a green circle denote a custom-made product.)



■Dimensions (mm) and Weights (kg)

Nominal size	L	H	H ₁	Plug	Weight
15A	175	177	98	NPT 3/8	4.5
20A	195	177	98	NPT 3/8	4.9
25A	215	177	98	NPT 3/8	6.2
32A	280	336	190	NPT 1/2	18.3
40A	280	336	190	NPT 1/2	18.7
50A	290	336	190	NPT 1/2	19.6

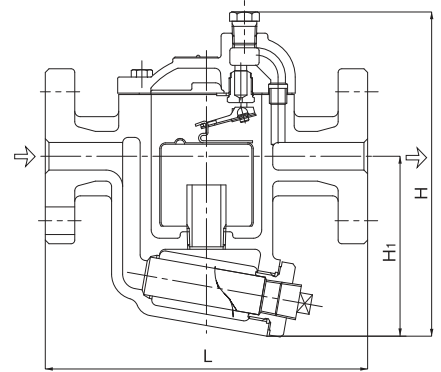

■Options

(The options listed below are made-to-order items. For further information, please contact us.)

- Large vent (LV)
- Thermic vent bucket (T)
- Scrub wire (VW)
- Built-in type check valve (V)

* Only either a built-in type check valve or a thermic vent bucket can be installed on 15A to 25A steam traps.



■Exploded View

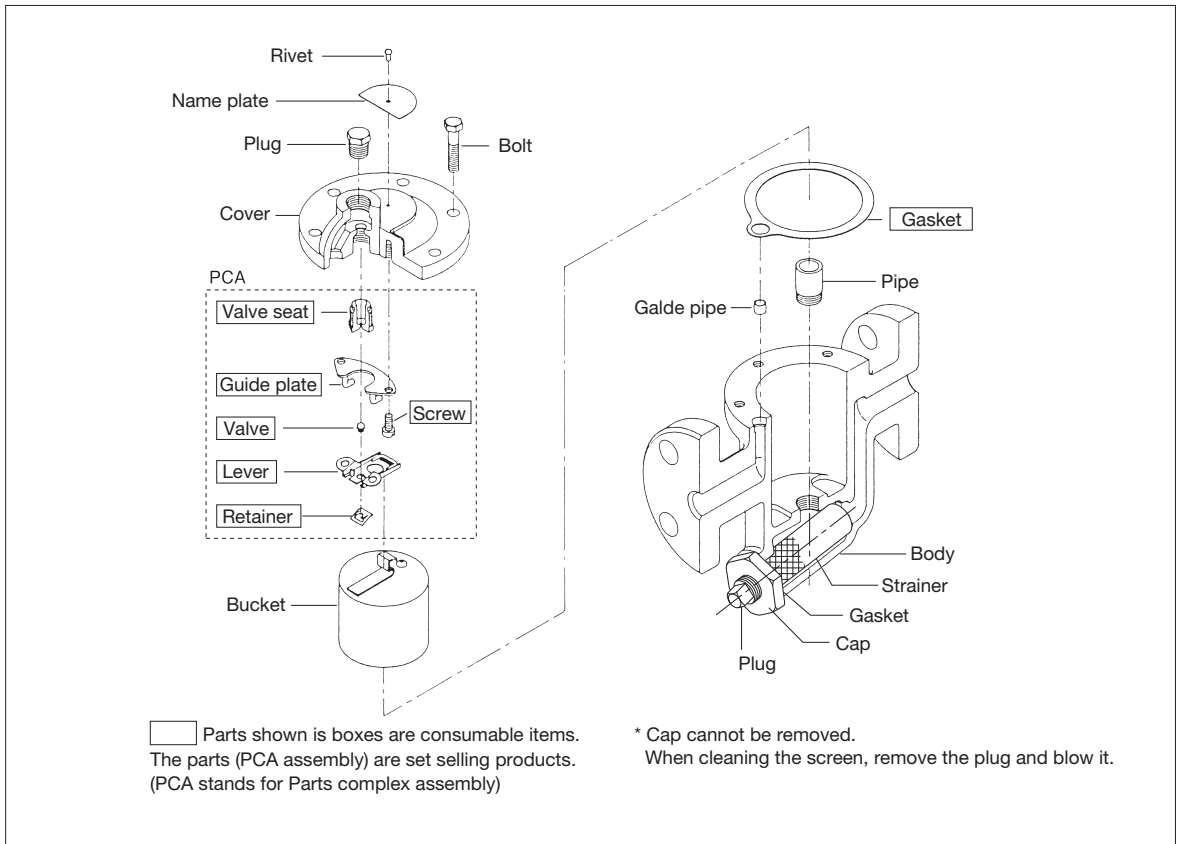



TSF-8

Bucket	Float	Disc	Bellows
Bimetal	Wafer	By-pass	Stainless steel
Connector	Right to Left	Down to Up	Up to Down

■Features

1. The TSF-8 can discharge condensate effectively without retention due to reliable operation by difference in specific gravity between steam and condensate.
2. Since the main parts are attached on the cover and it is possible to dismount the cover with the body connected to the piping, inspection and parts replacement can be conducted easily.
3. Excellent corrosion resistance and durability because the main parts are all made of stainless steel.
4. A strainer is incorporated to protect the internal parts from foreign substances and improve durability.

■Specifications

Model	TSF-8
Nominal size	15A, 20A, 25A
Application	Steam condensate
Working pressure (Max. working differential pressure)	TSF-8-5 : 0.01-0.5 MPa (0.5 MPa) TSF-8-10: 0.01-1.0 MPa (1.0 MPa) TSF-8-21: 0.01-2.1 MPa (2.1 MPa)
Max. temperature	220°C
Material	Body
	Float
	Valve, valve seat
Connection	JIS Rc screwed

■Caution for Installation

<Flow direction>

- Standard flow direction is Left to Right, however; the direction can be changed at your site.
Please refer to “Reassembly Procedures for Flow Direction Change.”
- If you reassemble the product and change its flow direction, inscribe the symbol on the plate according to the new flow direction. “V” for “Top to Bottom” flow, and “R” for “Right to Left” flow.

Flow direction	Symbol
Left to Right (Pre-set)	Blank
Top to Bottom	V
Right to Left	R

* Available Bottom and Top.
Please apply that shorten the vertical piping before the trap to open and discharge easily of trap in the condition of using upward flow direction.

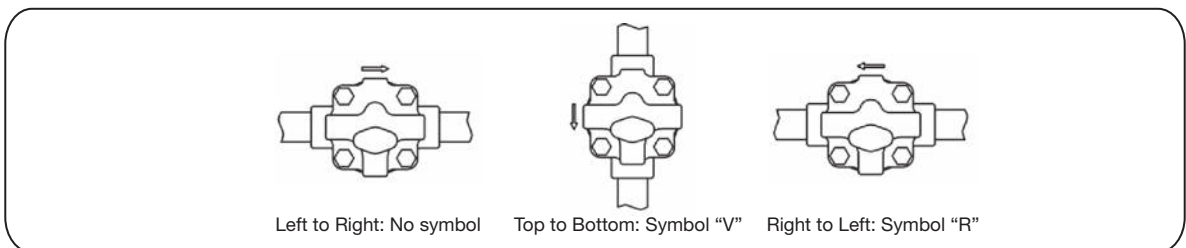

■ Dimensions (mm) and Weights (kg)

Nominal size	d	L	A	A ₁	H	Weight
15A	Rc 1/2	121	147	90	113	3.7
20A	Rc 3/4	121	147	90	113	3.7
25A	Rc 1	145	147	90	113	4.1

5
Steam Trap

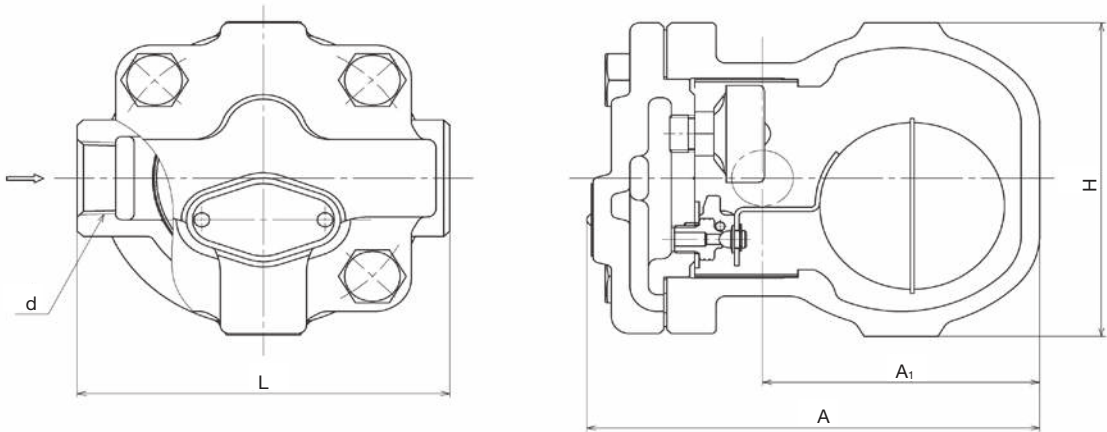

■ Maximum Continuous Discharge Capacity Chart

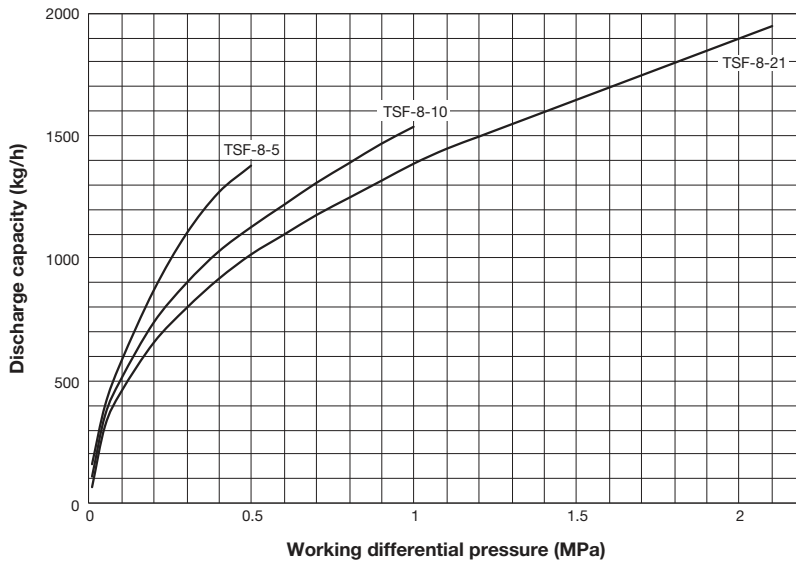

The discharge capacity shown on the above chart is the maximum value. In designing a system, select a steam trap with a sufficient safety factor (more than two times the regular level).



TSF-10, 10F, 11, 11F



Bucket	Float	Disc	Bellows
Bimetal	Wafer	By-pass	Stainless steel
Connector	Right to Left	Down to Up	Up to Down

■Features

1. The TSF-10 · 10F · 11 · 11F can discharge condensate effectively without retention, and realize energy saving steam system without steam loss.
2. Incorporated thermostatic air vent discharges air inside the piping and shortens warming-up time.
3. With turning the cock, it is possible to meet various flow direction such as horizontal or vertical installation.

Flow direction can be switched easily without disassembly such as detaching the cover.

4. Since the main parts are installed on the cover and it is possible to disassemble the cover with the body installed on the piping, and inspection and parts replacement can be conducted easily.



TSF-10,11

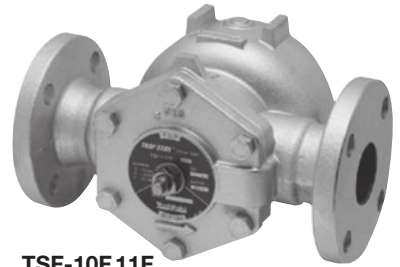

TSF-10F,11F

■Specifications

Model	TSF-10	TSF-10F	TSF-11	TSF-11F
Nominal size	15A-25A		25A-50A	
Application	Steam condensate			
Working pressure	TSF-1□□-5: 0.01-0.5 MPa TSF-1□□-10: 0.01-1.0 MPa TSF-1□□-21: 0.01-2.1 MPa			
Maximum temperature	220°C			
Material	Body	Ductile cast iron		
	Float	Stainless steel		
	Valve, valve seat	Stainless steel		
Connection	JIS Rc screwed NPT screwed	JIS 10K FF flanged JIS 20K FF flanged	JIS Rc screwed NPT screwed	JIS 10K FF flanged JIS 20K FF flanged

■Caution for Installation

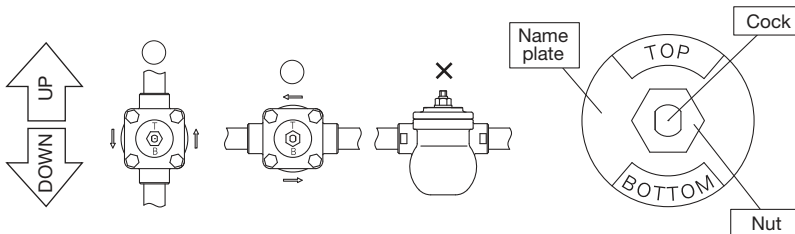

Adjust direction of the name plate in no pressure condition after installation.

Fix the cock with spanner and loosen the nut. Turn the cock and adjust direction of the name plate to position "TOP" and "BOTTOM" signs on upside and downside respectively. Fix the cock with spanner and fasten the nut after adjustment.

* In case of Bottom to Top, Please apply that shorten the vertical piping before the trap to open and discharge easily of trap in the condition of using upward flow direction.

■ Dimensions (mm) and Weights (kg)

· TSF-10

Nominal size	d	L	A	A ₁	H	Weight
15A	Rc 1/2	121	167	90	113	3.6
20A	Rc 3/4	121	167	90	113	3.6
25A	Rc 1	145	167	90	113	4.0

· TSF-10F

Nominal size	d	L	A	A ₁	H	Weight
15A	15	175	167	90	113	5.0
20A	20	195	167	90	113	5.8
25A	25	215	167	90	113	7.1

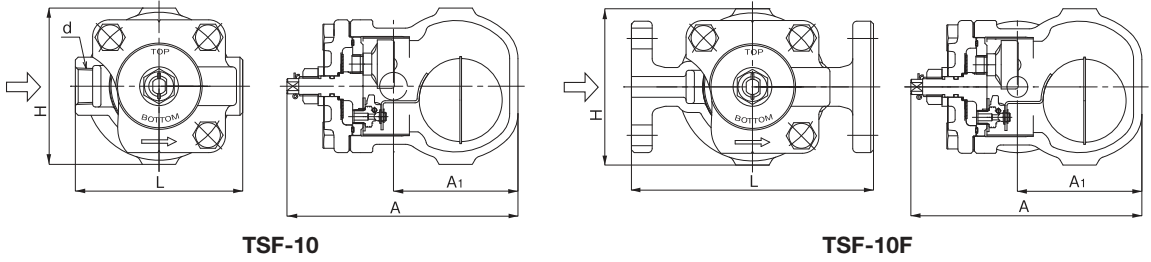

■ Maximum Continuous Discharge Capacity Chart

· TSF10, 10F

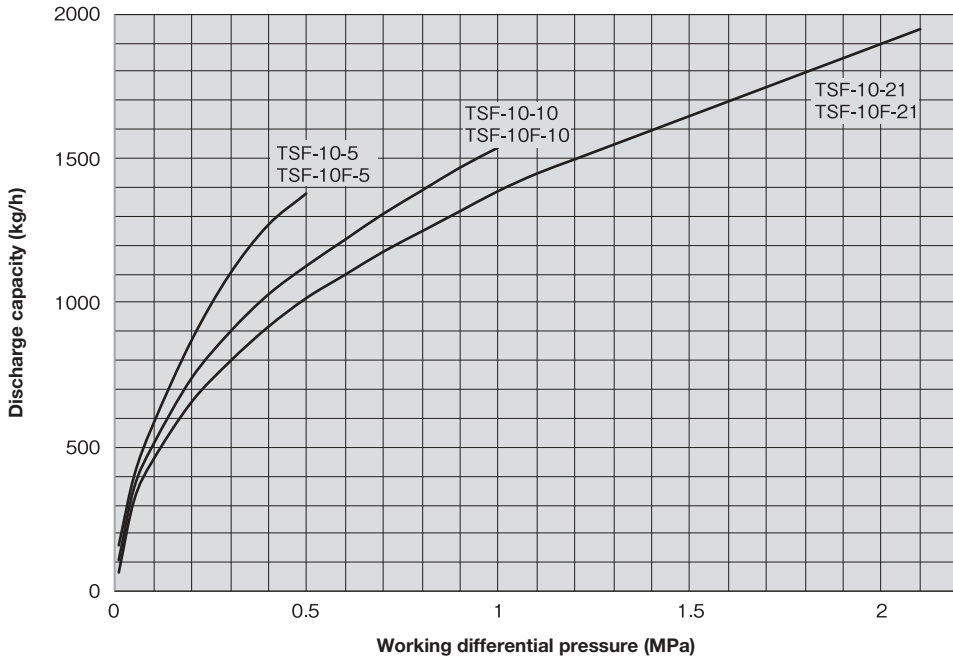

The discharge capacity shown in the charts on the above is the maximum value. In designing a system, select a steam trap with a sufficient safety factor (more than two times the regular level).



■ Dimensions (mm) and Weights (kg)

· TSF-11

Nominal size	d	L	A	A ₁	H	Weight
25A	Rc 1	190	244	147	186	9.9
32A	Rc 1-1/4	190	244	147	186	10.0
40A	Rc 1-1/2	205	244	147	186	10.2
50A	Rc 2	220	244	147	186	10.5

· TSF-11F

Nominal size	d	L	A	A ₁	H	Weight
25A	25	270	244	147	186	13.4
32A	32	270	244	147	186	14.1
40A	40	280	244	147	186	14.4
50A	50	290	244	147	186	15.5

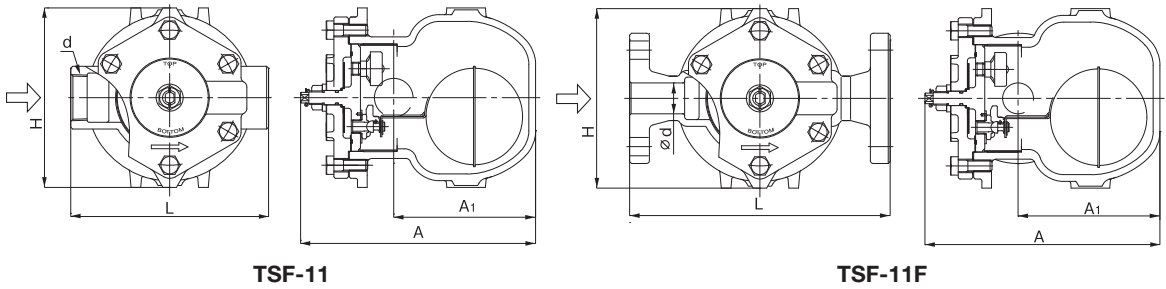

■ Maximum Continuous Discharge Capacity Chart

· TSF11, 11F

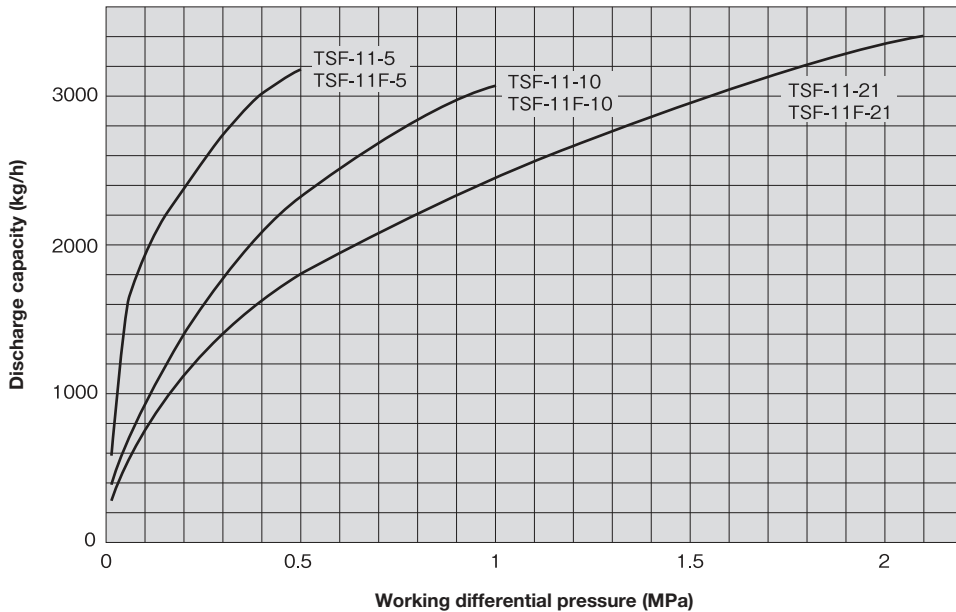

The discharge capacity shown in the charts on the above is the maximum value. In designing a system, select a steam trap with a sufficient safety factor (more than two times the regular level).



TSF-12

Bucket	Float	Disc	Bellows
Bimetal	Wafer	By-pass	Stainless steel
Connector	Right to Left	Down to Up	Up to Down



5 Steam Trap

■Features

1. Reliable performance and large discharge capacity ensured by lever float system.
2. All main parts such as valves, seats, air vents and floats are made of stainless steel that offer excellent corrosion resistance and durability.
3. By adopting the high-pressure air vent, to exhaust the air in the steam piping system quickly, significantly shorten the equipment start-up time.

■Specifications

Model		TSF-12	
Nominal size		40A , 50A	
Application		Steam condensate	
Working pressure (Max. working differential pressure)		TSF-12-1: 0.01-0.1 MPa (0.1 MPa) TSF-12-2: 0.01-0.2 MPa (0.2 MPa) TSF-12-5: 0.01-0.5 MPa (0.5 MPa)	TSF-12-9: 0.01-0.9 MPa (0.9 MPa) TSF-12-12: 0.01-1.2 MPa (1.2 MPa) TSF-12-17: 0.01-1.7 MPa (1.7 MPa)
Maximum temperature		230°C	
Material	Body	Ductile cast iron	
	Float	Stainless steel	
	Valve, Valve seat	Stainless steel	
Connection		JIS Rc screwed NPT screwed	

■Caution for Installation

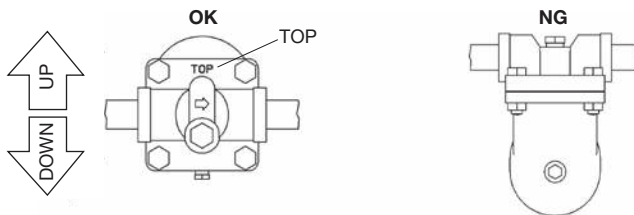

- To install the product, confirm if the direction of fluid flow matches with inlet and outlet sides of the product and install the product correctly.
- * Setting the product in wrong directions prevents it from functioning properly.
 - Check installation posture. Do not tilt the product during use.
 - * Wrong posture hampers proper operation.



■ Dimensions (mm) and Weights (kg)

Nominal size	d	L	A	A ₁	H	Weight
40A	Rc 1-1/2	200	308	266	228	21.7
50A	Rc 2	200	361	319	285	24.6

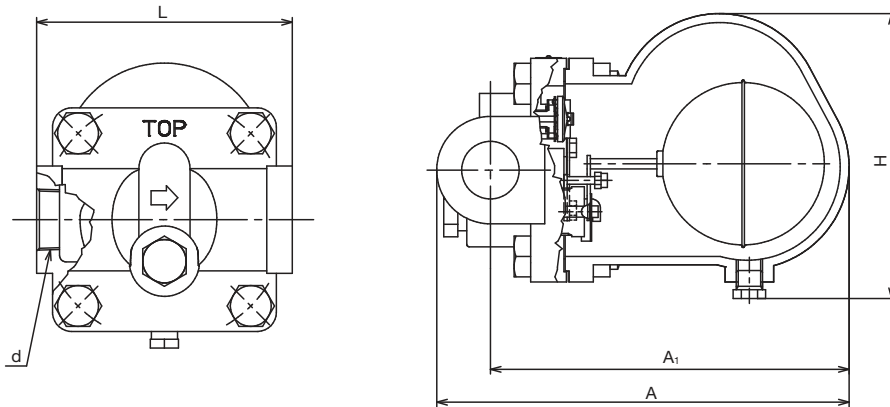

■ Maximum Continuous Discharge Capacity Chart

· Nominal size: 40A

· Nominal size: 50A

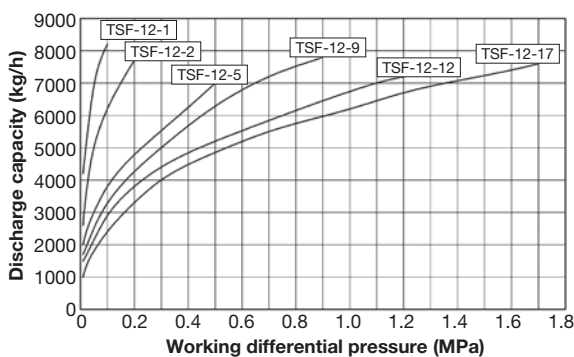
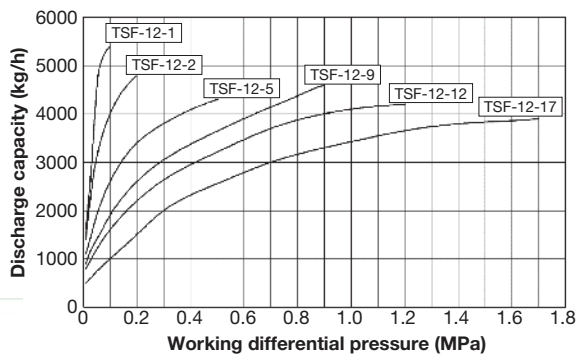

The discharge capacity shown in the charts on the above is the maximum value. In designing a system, select a steam trap with a sufficient safety factor (more than two times the regular level).



TF-1,2

Bucket	Float	Disc	Bellows
Bimetal	Wafer	By-pass	Stainless steel
Connector	Right to Left	Down to Up	Up to Down

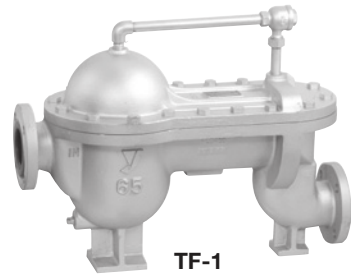

TF-1

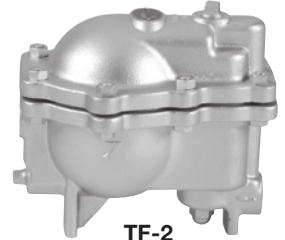

TF-2

■ Features

1. The stainless steel valve disc and valve seat offer excellent durability (TF-2).
2. Built-in air vent prevents air-binding problem, offering higher durability.
3. Reliable performance and large discharge capacity ensured by lever float system.

■ Specifications

Model	TF-1	TF-2	
Application	Steam condensate		
Working pressure	0.01-0.3 MPa	0.01-0.7 MPa	
Max. temperature	150°C	170°C	
Material	Body	Ductile cast iron	
	Valve, valve seat	Cast bronze	Stainless steel
	Float	Brass	Stainless steel
Connection	JIS 10K RF flanged	JIS Rc screwed	

■ Dimensions (mm) and Weights (kg)

· TF-1

Nominal size	L	H	H ₁	H ₂	Weight
65A	680	530	260	100	84
80A	680	530	260	100	84

· H₁ and H are reference values.

· TF-2

Nominal size	d	L	H	H ₁	H ₂	Weight
15A	Rc 1/2	257	252	122	42	13.3
20A	Rc 3/4	257	252	122	42	13.3
25A	Rc 1	290	266	122	42	15.5
32A	Rc 1-1/4	290	266	122	42	15.5
40A	Rc 1-1/2	335	310	159	45	19.2
50A	Rc 2	335	310	159	45	19.2

· H₁, H₂, and H are reference values.

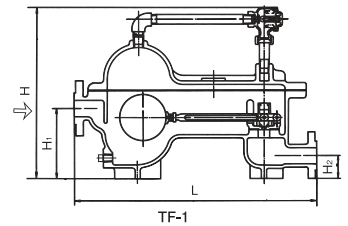

TF-1

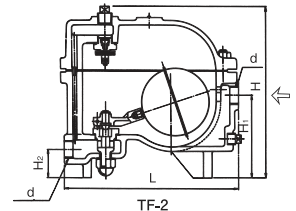

TF-2

■ Maximum Continuous Discharge Capacity

· TF-1

Nominal size	Working differential pressure MPa					
	0.05	0.10	0.15	0.20	0.25	0.30
65A	6,500	8,700	10,000	11,000	13,000	13,000
80A	6,500	8,700	10,000	11,000	13,000	13,000

· The discharge capacities shown in the table and chart are the maximum values. In designing a system, select a steam trap with a sufficient safety factor (three times to five times the regular level).

· TF-2

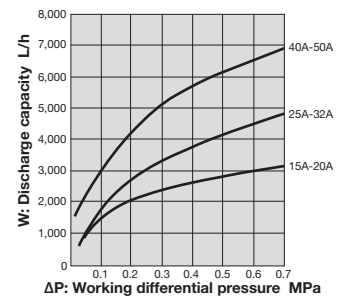

· In general, select a steam trap with a safety factor twice or threefold the regular level.





TS-7,8

- Bucket
- Float
- Disc
- Bellows**
- Bimetal
- Wafer
- By-pass**
- Stainless steel
- Connector
- Right to Left**
- Down to Up**
- Up to Down**



TS-7

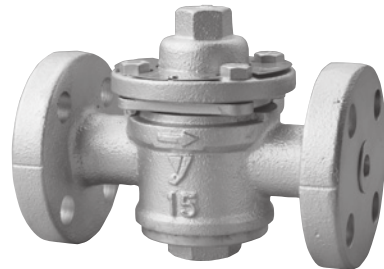

TS-8

■Features

1. Four functions (STOP / BY-PASS / TRAP / TEST) can be switched easily with a spanner or monkey wrench.
2. The integrated bypass function helps reduce piping and construction work costs significantly.
3. Applicable in wide working pressure range due to welded bellows.
4. Works at a 12°C lower temperature than the saturating temperature and discharges no live steam.
5. Trap check can be performed without being affected by back pressure.
6. The cock and valve, both made of stainless steel, are integrated into one unit.
7. Equipped with built-in strainer.
8. Installable in any direction.

■Specifications

Model	TS-7	TS-8
Application	Steam condensate	
Maximum pressure	1.0 MPa *	
Minimum working differential pressure	0.03 MPa	
Max. temperature	183°C	
Material	Body	Ductile cast iron
	Cock (Valve seat)	Stainless steel
	Bellows (Valve)	Stainless steel
	Strainer	Stainless steel
Connection	JIS Rc screwed	JIS 10K FF flanged

* When performing an airtightness test using water or air, keep the pressure at 0.5 MPa or less.



■ Dimensions (mm) and Weights (kg)

· TS-7

Nominal size	d	L	Weight
15A	Rc 1/2	107	2.3
20A	Rc 3/4	109	2.4
25A	Rc 1	115	2.5

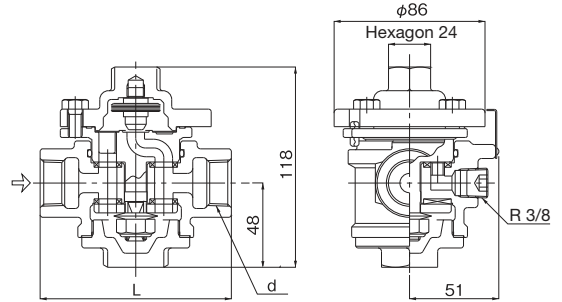

TS-7

· TS-8

Nominal size	L	Weight
15A	156	3.9
20A	160	4.4
25A	160	5.5

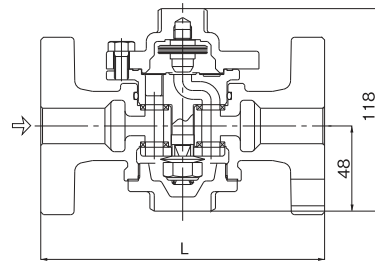

TS-8

■ Maximum Continuous Discharge Capacity Chart

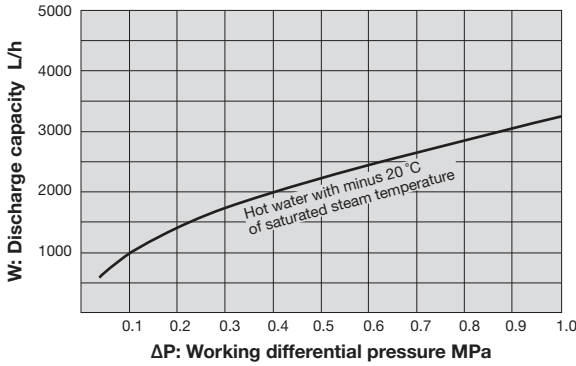

■ Maximum Continuous Discharge Capacity Table

Differential pressure MPa	0.03	0.05	0.1	0.2	0.3	0.4	0.5	0.6	0.7	0.8	0.9	1.0
Hot water with minus 20 °C of saturated steam temperature	560	730	1020	1450	1780	2050	2300	2500	2700	2900	3100	3250

(L/h)

· The discharge capacities shown in the chart and table above are the maximum values. In designing a system, select a steam trap with a sufficient safety factor (at least three times the regular level).

TSD-7,7F

- Bucket
- Float
- Disc**
- Bellows
- Bimetal
- Wafer
- By-pass**
- Stainless steel
- Connector
- Right to Left**
- Down to Up**
- Up to Down**

■Features

1. Four functions (STOP / BY-PASS / TRAP / TEST) can be switched easily with a spanner or monkey wrench.
2. The integrated bypass function helps reduce piping and construction work costs significantly.
3. Bimetal solves air-binding problem and ensures a smooth discharge of cold condensate or air at the start of operation, enabling steam equipment to efficiently start to run.
4. Can be checked without being affected by back pressure.
5. The stainless steel valve disc and valve seat are subjected to special heat treatment and very durable.
6. Equipped with a built-in strainer.
7. Can be installed vertically or horizontally as desired.
8. Rain cover is available as options for outdoor use.



TSD-7

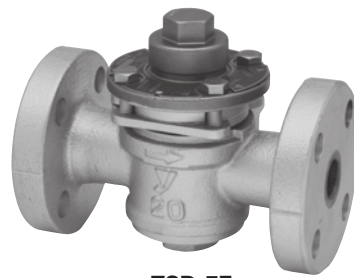

TSD-7F

■Specifications

Model	TSD-7	TSD-7F
Application	Steam condensate	
Working pressure	0.035-1.0 MPa	
Allowable back pressure	50% of inlet pressure	
Maximum temperature	183°C	
Installation posture	At any angle between vertical and horizontal (Do not put the cover under the horizontal level.)	
Material	Body	Ductile cast iron
	Disc, seat	Stainless steel (special heat treatment)
Connection	JIS Rc screwed	JIS 10K FF flanged

■Maximum Continuous Discharge Capacity Chart

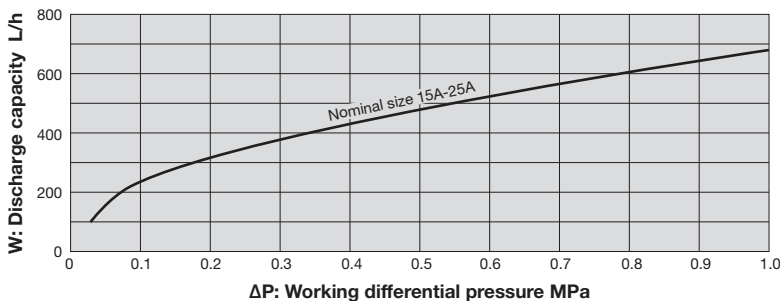

The discharge capacity shown on the above chart is the maximum value. In designing a system, select a steam trap with a sufficient safety factor (four to five times the regular level). That is, for example, if a discharge capacity of 100 kg/h is required, select a steam trap capable of discharging 400 to 500 kg/h.



■ Dimensions (mm) and Weights (kg)

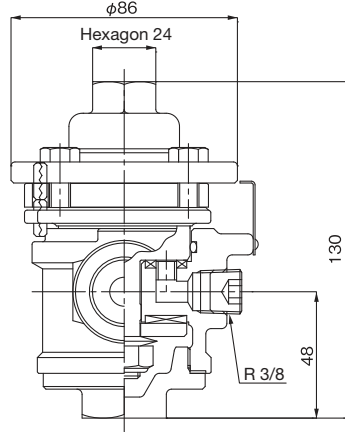
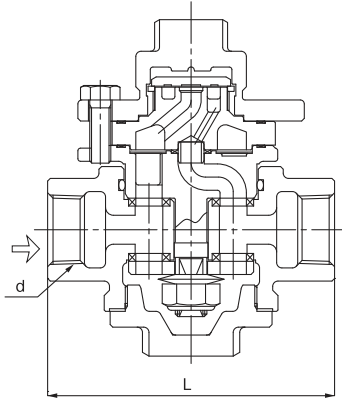

· TSD-7

Nominal size	d	H	Weight
15A	Rc 1/2	107	2.5
20A	Rc 3/4	109	2.6
25A	Rc 1	115	2.7

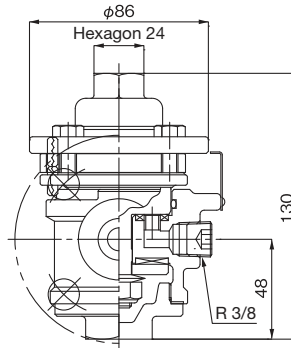
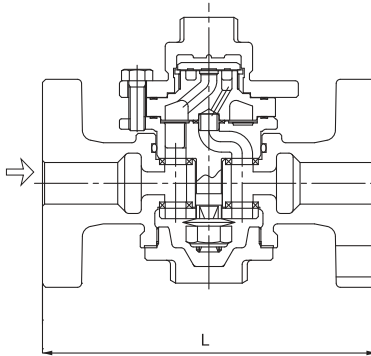

· TSD-7F

Nominal size	L	Weight
15A	156	4.1
20A	160	4.6
25A	160	5.7

■ Option

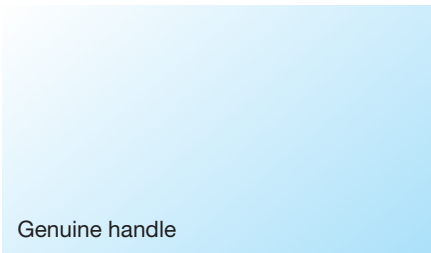

It can operate safely and easily switching.



It can effect on prevention of working blank shot from wet rain.





■ Switching Mechanism and Operation

	STOP	BY-PASS	TRAP	TEST
Position				
Operation				
Conventional piping				

Steam
 Condensate

· All steam traps are set at the "STOP" position when delivered.

1. STOP: Fluid does not flow into the trap and out of the bypass because the inlet, the outlet, and the bypass are closed, and the strainer can be cleaned and the bellows can be inspected.
2. BY-PASS: Fluid flows through the bypass directly to the outlet. Select this position when blowing the piping during plumbing or discharging a large quantity of condensate before starting operation. Since fluid does not flow to the trap, the strainer can be cleaned and the bellows can be inspected.
3. TRAP: In this position, the steam trap performs regular trap operation, and condensate flows from the inlet to the outlet through the trap. It does not flow out of the bypass.
4. TEST: In this position, condensate is discharged from the inlet to the outlet for testing through the trap, and the operation of the trap can be checked. This check can be carried out with the outlet closed and without being affected by back pressure. Fluid does not flow out of the bypass.

■ Precaution for Installation

1. Carefully blow the piping before connecting the steam trap.
2. Connect the steam trap to the piping according to its arrow indicating the direction of flow.
3. Slope the piping and place the product at as a low position as possible in order to make condensate flow into the product by its own weight.
4. Do not insulate the piping inlet and the steam trap.
5. To install the product in a main steam pipe, provide a drip leg at the inlet side of the product.
6. Secure enough space for switching operation of the cock and maintenance (such as cleaning the strainer and inspection of the bellows).
7. If discharge capacity is not enough, install more than one trap. In this case, connect the traps to the piping so that their inlets are in the same level.
8. Do not install the steam trap in a place where ambient temperature is higher than the condensate to be discharged.

■ Piping Example

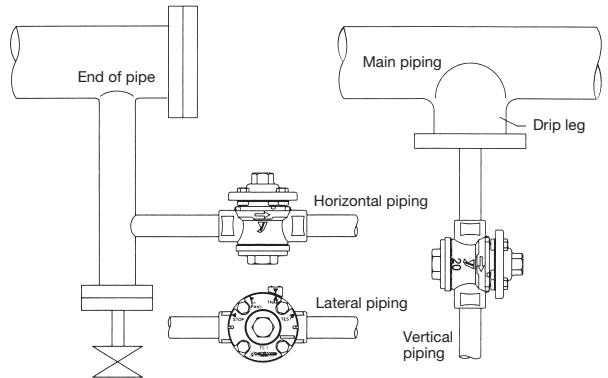

TD-10NA, 30NA

- Bucket
- Float
- Disc**
- Bellows
- Bimetal
- Wafer
- By-pass
- Stainless steel
- Connector
- Right to Left**
- Down to Up**
- Up to Down**

5 Steam Trap

■Features

1. Bimetal solves air-binding problem and ensures a smooth discharge of cold condensate or air at the start of operation, enabling steam equipment to efficiently start to run.
2. The stainless steel valve disc and valve seat, which are subjected to special heat treatment, offers excellent durability.
3. The valve disc, valve seat and bimetal can be replaced on site without disconnecting the steam trap from the piping.
4. Easy maintenance and inspection due to simple structure: the valve disc is only movable part.
5. Compact, lightweight and inexpensive. Applicable in wide working pressure range and adjustment-free.
6. Installable in any direction and easy to plumb.
7. Free of improper operation and steam leakage due to air insulation type.
8. Built-in strainer eliminates requirement for strainer before the product.
9. Large discharge capacity.



TD-10NA

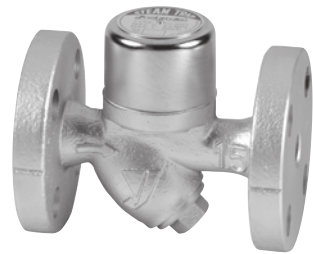

TD-30NA

■Specifications

Model	TD-10NA	TD-30NA	
Nominal size		15-25A	
Application		Steam condensate	
Working pressure	0.035-2.0 MPa	0.035-1.0 MPa	0.035-2.0 MPa
Allowable back pressure		50% or less of inlet pressure	
Max. temperature		220°C	
Connection	JIS Rc screwed	JIS 10K FF flanged	JIS 20K FF flanged
Material	Body	Ductile cast iron	
	Disc, seat	Stainless steel (special heat treatment)	





■ Dimensions (mm) and Weights (kg)

· TD-10NA

Nominal size	d	L	H ₁	H ₂	Weight
15A	Rc 1/2	90	49	55.5	0.9
20A	Rc 3/4	90	53	60.5	1.2
25A	Rc 1	90	56	62.5	1.4

· TD-30NA

Nominal size	L	H ₁	H ₂	Weight
15A	125	51	59	2.3
20A	140	54	63	3.4
25A	150	65	63	4.1

- The dimensions of the product with JIS 10K FF flanged and the product with JIS 20K FF flanged are identical.
- The thickness of JIS 10K FF flanges conforms to that of JIS 20K FF flanges.

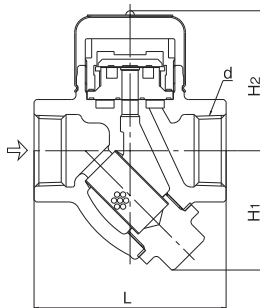

TD-10NA

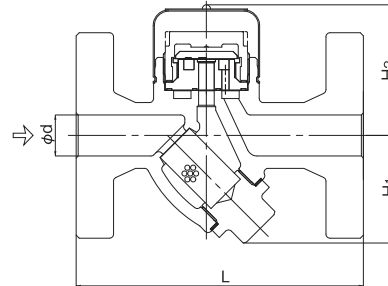

TD-30NA

■ Maximum Continuous Discharge Capacity Chart

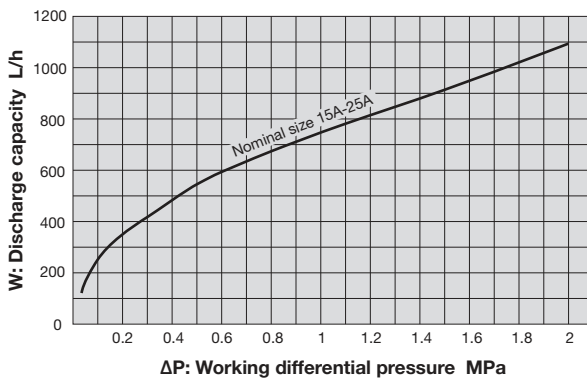

■ Installation Posture

* The steam trap can be installed horizontally, sidlingly, or vertically.

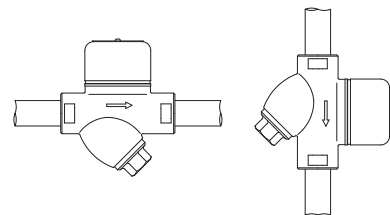

* The discharge capacity shown on the above chart is the maximum value. In designing a system, select a steam trap with a sufficient safety factor (four to five times the regular level). That is, for example, if a discharge capacity of 100 kg/h is required, select a steam trap capable of discharging 400 to 500 kg/h.

TSD-42

- Bucket Float **Disc** Bellows
- Bimetal Wafer By-pass **Stainless steel**
- Connector **Right to Left** **Down to Up** **Up to Down**

5 Steam Trap

■Features

1. Stainless steel used for main parts, making a contribution to improve corrosion resistance.
2. Since it can operate under 425°C temperature and 4.2 MPa pressure conditions, it can be applied in various types of industries, such as heavy, light, and general industries.
3. Bimetal solves air-binding problem and ensures a smooth discharge of cold condensate or air at the start of operation, enabling steam equipment to efficiently start to run.
4. "Insulation cover" avoids frequent on-off operation.
5. Plumbing is easy to perform because it can be installed vertically or horizontally as desired.
6. Built-in strainer eliminates requirement for strainer before the trap.



■Specifications

Model		TSD-42
Application		Steam condensate
Working pressure		0.035-4.2 MPa
Allowable back pressure		50% or less of inlet pressure
Maximum temperature		425°C
Material	Body	Stainless steel (SCS2A)
	Disc, seat	Stainless steel (special heat treatment)
Connection		JIS Rc, NPT, BSPT screwed

■Dimensions (mm) and Weights (kg)

Nominal size	L	H	H ₁	A	Weight
10A	78	76	23	32	0.65
15A	78	76	23	32	0.6
20A	85	79	24	38	0.7
25A	95	86	27.5	45	0.9

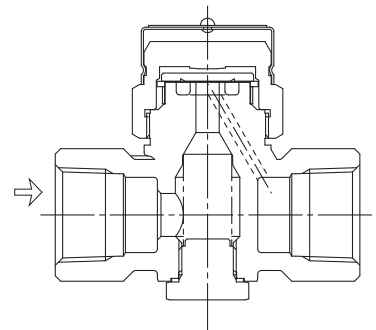
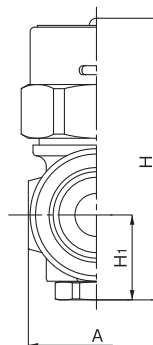
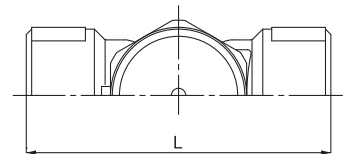

■ Maximum Continuous Discharge Capacity

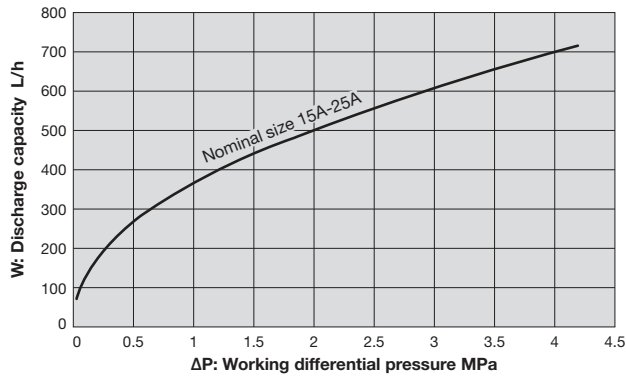

- To select the product size, secure the safety factor of 4 to 5. For example, if you need a steam trap with a capacity of 100 kg/h, the trap with a capacity of 400 to 500 kg/h should be selected for maximum efficiency.
- The back pressure (outlet pressure) should be considered in selecting discharge capacity. This is because discharge capacity of a trap depends on the operating differential pressure (the difference between the inlet and the outlet pressures). For example, to find the discharge capacity obtained by the inlet pressure is 1.0 MPa and the outlet pressure is 0.2 MPa, trace up from the point of the operating differential pressure of 0.8 MPa in the above chart.

■ Installation Posture

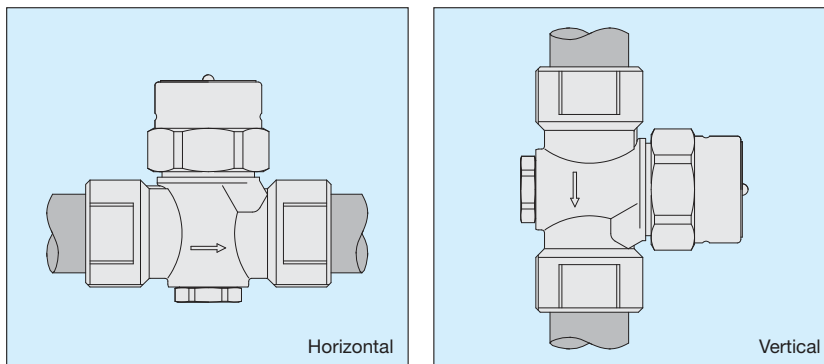



KASKO DEMİRÇELİK MAKİNE VE İNŞAAT SANAYİ TİCARET LİMİTED ŞİRKETİ

**Güzelyurt Mah. Mehmet Akif Ersoy Cad. No: 38 Gökdemir Plaza Kat: 3 Ofis: 24 Zip Code:
34524 Esenyurt / İSTANBUL**

Tel: +90 850 441 25 67

Cell: +90 541 699 01 34

info@kaskomakine.com

kaskomakine.com