

TABLE OF CONTENTS

7	FIGURE NUMBER SYSTEM	1
2	Y STRAINER	2~4
3	CONICAL STRAINER	4
4	BASKET STRAINER	5~6
5	T STRAINER	7~8
6	INSTALLATION MAINTENANCE AND OPERATING INSTRUCTION	9

FIGURE NUMBER SYSTEM

1. VALVE TYPE	CYS=Y STRAINER CTS=T STRAINER CBS=BASKET STRAINER CCS=CONICAL STRAINER		
2. SIZE	02=2" 21=2 1/2" 03=3" 04=4" 05=5" 06=6" 08=8"	10=10" 12=12" 14=14" 16=16" 18=18" 20=20" 24=24"	26=26" 28=28" 30=30" 36=36" 40=40" 42=42"
3. PRESSURE	01=ANSI CLASS 150 03=ANSI CLASS 300 06=ANSI CLASS 600	09=ANSI CLASS 900 15=ANSI CLASS 1500	
4. ENDS	RF=RAISED FACE FLANGED END NT= NPT FEMALE JF=RTJ FLANGED SN= SOCKET WELD x NPT FEMALE RW=RAISED FACE FLANGEDxWELDED END	BW=BUTT WELDED JW=RTJxWELDED FF=FLAT FACE SW= SOCKET WELD	
5. BODY MATERIAL	01=WCB/ A105 02= LCC/ Lf2 03= CF8M/ F316 04=DUPLEX F51 05=DUPLEX F55 06=A105N 07=WCB+ENP / A105+ENP 08=DUCTILE IRON 09=CF8/F304	10=WC6/ F11 11= C5/ F5 12=CF3/F304L 13=CF3M/F316L 14=MONEL 15=CN7M(ALLOY 20) 16=C12/F9 17=WC9/F22 18=CAST IRON	19=WCC 20=LCB 21=C12A/F91 22=F12 23=F321 24=WC1 25=BRONZE(B61/B62) 26=F60 27=HASTELLOY
6. SCREEN MATERIAL	S2=304SS S3=316SS S4=410SS/F6A S5=DUPLEX-A182 F51	S6=SUPER DUPLEX- A182 F55 S7=316LSS S8=304LSS S9=17-4PH	
7. MATERIAL TYPE	C=CASTING	F=FORGED	

1. PART NUMBER EXAMPLE:

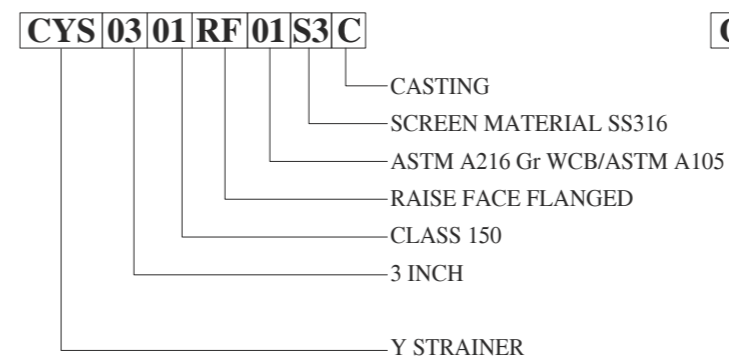

2. SERIES NUMBER EXAMPLE:

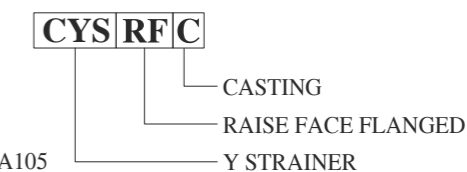

Y STRAINER

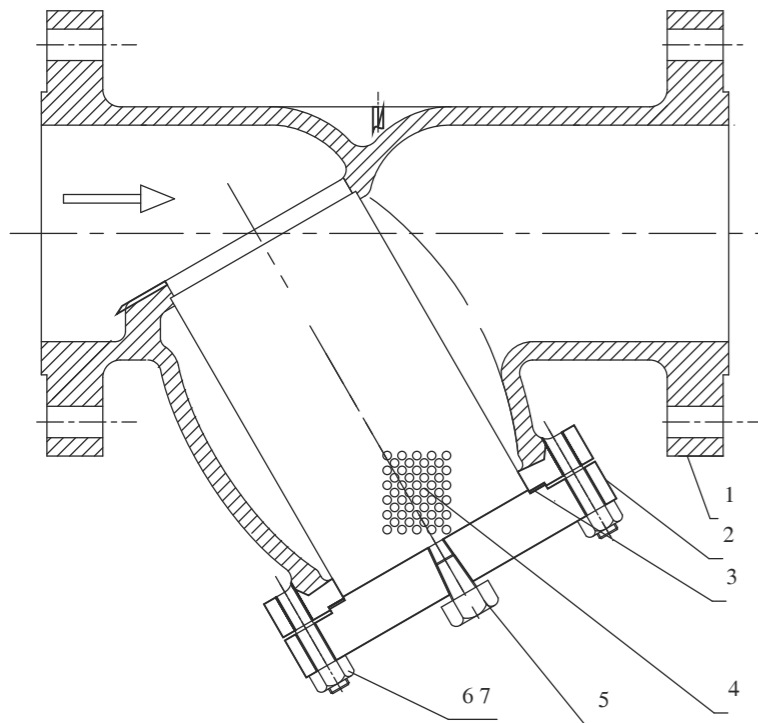

STANDARDS:

DESIGN AND MANUFACTURE:	ASME B16.34
FACE TO FACE DIMENSIONS:	ASME B16.10(CHECK VALVE/GLOBE VALVE) OR MANUFACTURER'S SPECIFICATION
FLANGED ENDS DIMENSIONS:	
NPS1/2"~24"	ASME B16.5
NPS26"~36"	ASME B16.47
BW ENDS DIMENSIONS:	ASME B16.25
SOCKET WELD ENDS DIMENSIONS:	ASME B16.11
PRESSURE-TEMPERATURE RATINGS:	ASME B16.34
PRESSURE:	CLASS 150~1500
SIZE:	NPS 2"~36"

ITEM	PART NAME	STANDARD	STAINLESS STEEL
1	BODY	ASTM A216 WCB	ASTM A351 CF8M
2	BONNET	ASTM A216 WCB	ASTM A351 CF8M
3	GASKET	SS304/SS316+GRAPHITE/PTFE	
4	SCREEN	SS304/SS316	SS316
5	PLUG	AISI 1025	SS316
6	BOLT	ASTM A193 B7/B7M	ASTM A193 B8M
7	NUT	ASTM A194 2H/2HM	ASTM A194 8M

NOTE: OTHER MATERIALS ARE AVAILABLE UPON REQUEST

Y STRAINER

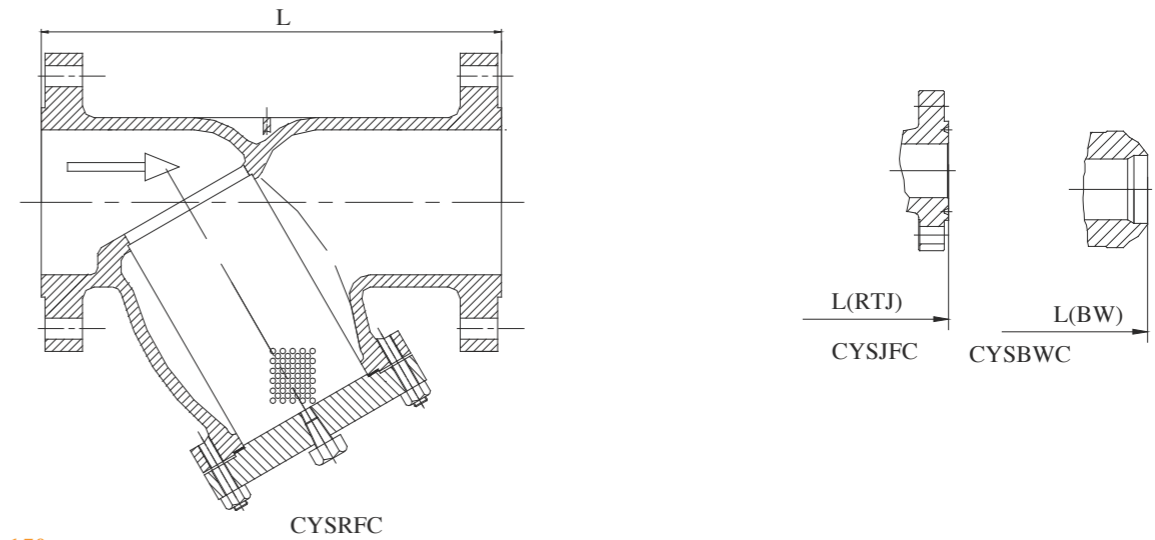

CLASS 150

NPS	in	2	2-1/2	3	4	5	6	8	10	12	14	16	18	20	24	30	36
DN	mm	50	65	80	100	125	150	200	250	300	350	400	450	500	600	750	900
L(RF)	mm	203	216	241	292	330	356	495	622	699	787	864	978	978	1295	1524	1956
L(BW)	mm	203	216	241	292	330	356	495	622	699	787	864	978	978	1295	1524	1956
L(RTJ)	mm	216	229	254	305	343	368	508	635	711	800	876	991	991	1308	1537	1968

CLASS 300

NPS	in	2	2-1/2	3	4	5	6	8	10	12	14	16	18	20	24	30
DN	mm	50	65	80	100	125	150	200	250	300	350	400	450	500	600	750
L(RF)	mm	267	292	318	356	400	445	533	622	711	838	864	978	1016	1346	1594
L(BW)	mm	267	292	318	356	400	445	533	622	711	838	864	978	1016	1346	1594
L(RTJ)	mm	282	308	333	371	416	460	549	638	727	854	879	994	1035	1368	1619

CLASS 600

NPS	in	2	2-1/2	3	4	6	8	10	12	14	16	18	20	24	30
DN	mm	50	65	80	100	150	200	250	300	350	400	450	500	600	750
L(RF)	mm	292	330	356	432	559	660	787	838	889	991	1092	1194	1397	1651
L(BW)	mm	292	330	356	432	559	660	787	838	889	991	1092	1194	1397	1651
L(RTJ)	mm	295	333	359	435	562	663	790	841	892	994	1095	1200	1407	1664

CLASS 900

NPS	in	2	2-1/2	3	4	6	8	10	12	14	16	18	20	24
DN	mm	50	65	80	100	150	200	250	300	350	400	450	500	600
L(RF)	mm	368	419	381	457	610	737	838	965	1029	1130	1219	1321	1549
L(BW)	mm	368	419	381	457	610	737	838	965	1029	1130	1219	1321	1549
L(RTJ)	mm	371	422	384	460	613	740	841	968	1038	1140	1232	1334	1568

CLASS 1500

NPS	in	2	2-1/2	3	4	6	8	10	12	14	16	18	20	24
DN	mm	50	65	80	100	150	200	250	300	350	400	450	500	600
L(RF)	mm	368	419	470	546	705	832	991	1130	1257	1384	1537	1664	1943
L(BW)	mm	368	419	470	546	705	832	991	1130	1257	1384	1537	1664	1943
L(RTJ)	mm	371	422	473	549	711	841	1000	1146	1276	1407	1559	1686	1972

Y STRAINER

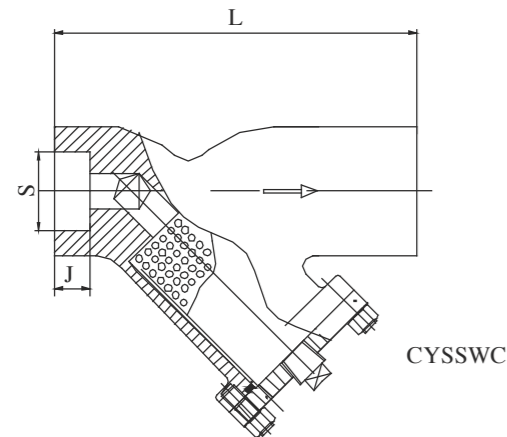

CYSSWC

CLASS 150~CLASS 1500

NPS	in	1/2	3/4	1	1-1/4	1-1/2	2
DN	mm	15	20	25	32	40	50
L	mm	130	130	140	160	170	200
S	mm	21.8	27.1	33.8	42.6	48.7	61.1
J	mm	10	13	13	13	13	16

CONICAL STRAINER

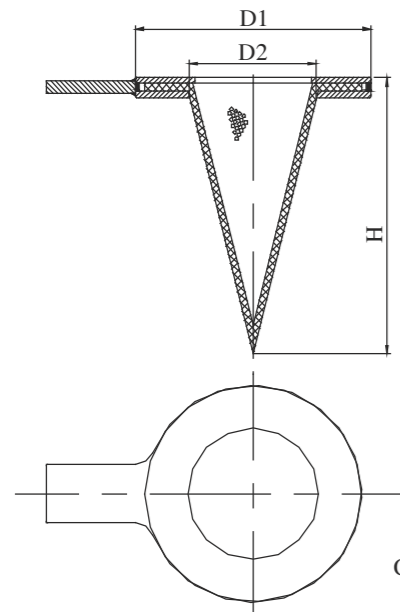

CCSRFF

STANDARDS:

DESIGN AND MANUFACTURE: MANUFACTURER'S SPECIFICATION
 FACE TO FACE DIMENSIONS: MANUFACTURER'S SPECIFICATION
 MATERIAL : STAINLESS STEEL

CLASS 150

NPS	in	2	2 1/2	3	4	6	8	10	12	14	16	18	20	24
DN	mm	50	65	80	100	150	200	250	300	350	400	450	500	600
D1	mm	92	105	127	157	216	270	324	381	413	570	533	581	692
D2	mm	44	55	65	90	140	190	240	285	335	366	410	460	560
H	mm	70	80	90	130	200	270	340	400	460	520	580	650	720

CLASS 300

NPS	in	2	2 1/2	3	4	6	8	10	12	14	16	18	20	24
DN	mm	50	65	80	100	150	200	250	300	350	400	450	500	600
D1	mm	92	105	127	157	216	270	314	381	413	470	533	584	692
D2	mm	44	55	64	90	140	190	240	285	335	366	410	460	560
H	mm	85	95	105	150	220	310	380	440	500	580	660	720	800

BASKET STRAINER

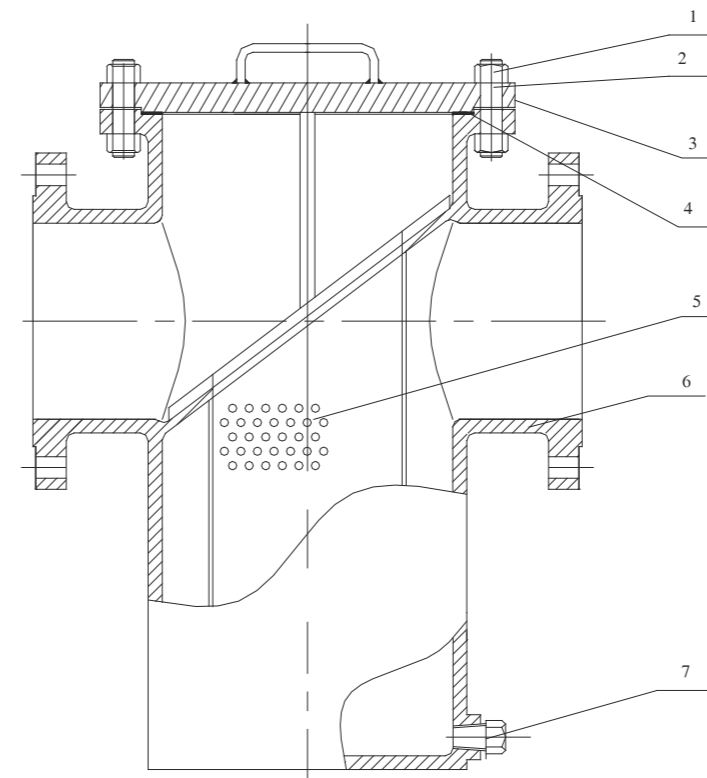

- DESIGN AND MANUFACTURE: ASME B16.34
- FACE TO FACE DIMENSIONS: ASME B16.10(CHECK VALVE/GLOBE VALVE)
- FLANGED ENDS DIMENSIONS: OR MANUFACTURER'S SPECIFICATION
- NPS 1/2"~24" ASME B16.5
- PRESSURE-TEMPERATURE RATINGS: ASME B16.34
- PRESSURE: CLASS 150~300
- SIZE: NPS 1/2"~16"

BILL OF MATERIAL (PARTIAL)

ITEM	PART NAME	STANDARD	STAINLESS STEEL
1	NUT	ASTM A194 2H/2HM	ASTM A194 8M
2	BOLT	ASTM A193 B7/B7M	ASTM A193 B8M
3	BONNET	ASTM A216 WCB	ASTM A351 CF8M
4	GASKET	SS304/SS316+GRAPHITE/PTFE	
5	SCREEN	SS304/SS316	SS316
6	BODY	ASTM A216 WCB	ASTM A351 CF8M
7	PLUG	AISI 1025	SS316

NOTE: OTHER MATERIALS ARE AVAILABLE UPON REQUEST

BASKET STRANIER

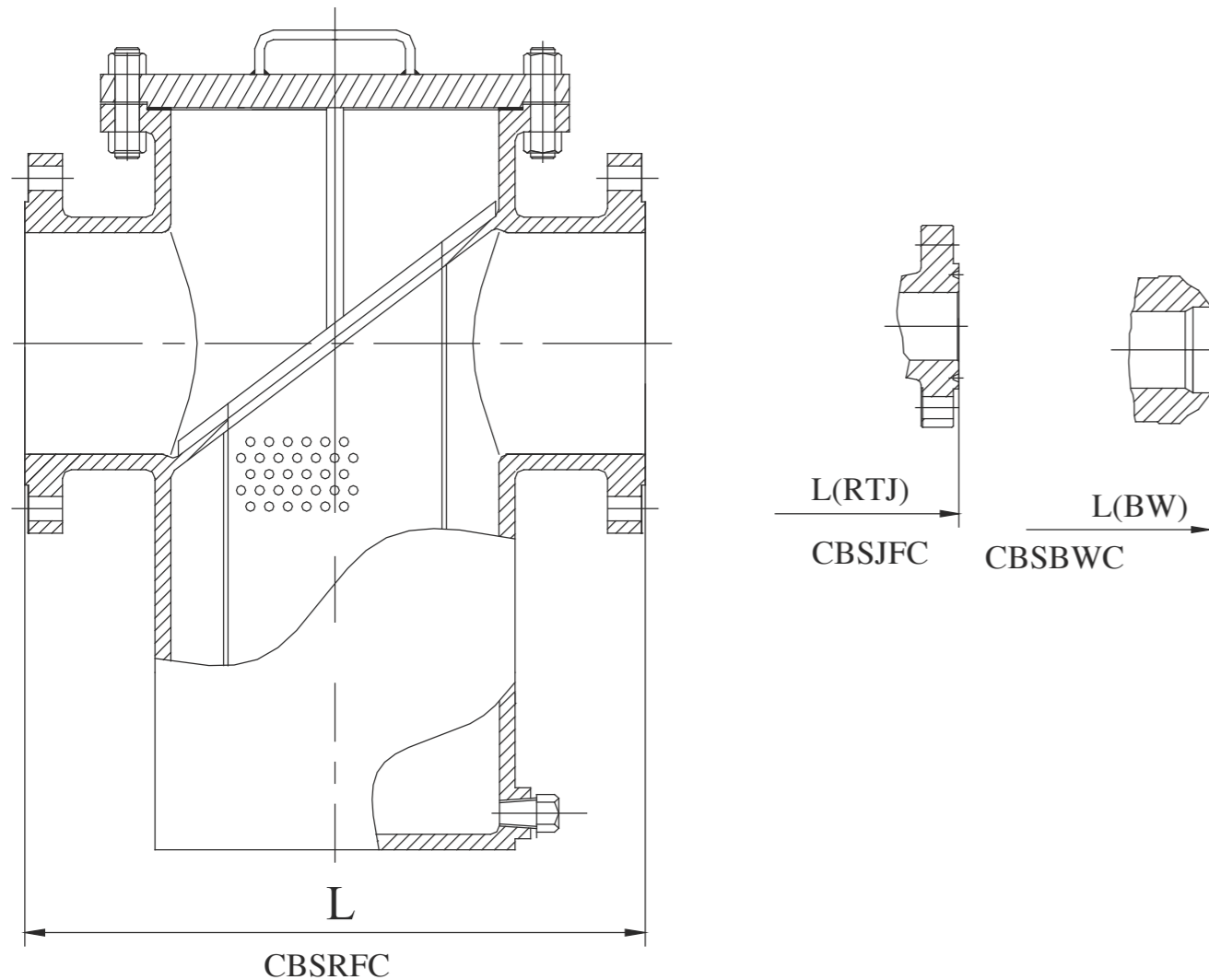

CLASS 150

NPS	in	1/2	3/4	1	1-1/4	1-1/2	2	2 1/2	3	4	5	6	8	10	12	14	16	18
DN	mm	15	20	25	32	40	50	65	80	100	125	150	200	250	300	350	400	450
L(RF)	mm	203	203	203	203	203	203	216	241	292	330	356	495	622	699	787	864	978
L(BW)	mm	203	203	203	203	203	203	216	241	292	330	356	495	622	699	787	864	978
L(RTJ)	mm	-	-	-	-	-	216	229	254	305	343	368	508	635	711	800	876	991

CLASS 300

NPS	in	1	1-1/4	1-1/2	2	2 1/2	3	4	5	6	8	10	12	14	16	18
DN	mm	25	32	40	50	65	80	100	125	150	200	250	300	350	400	450
L(RF)	mm	203	216	229	267	292	318	356	400	445	533	622	711	838	864	978
L(BW)	mm	203	216	229	267	292	318	356	400	445	533	622	711	838	864	978
L(RTJ)	mm	216	229	241	282	308	333	371	416	460	549	638	727	854	879	994

T STRANIER

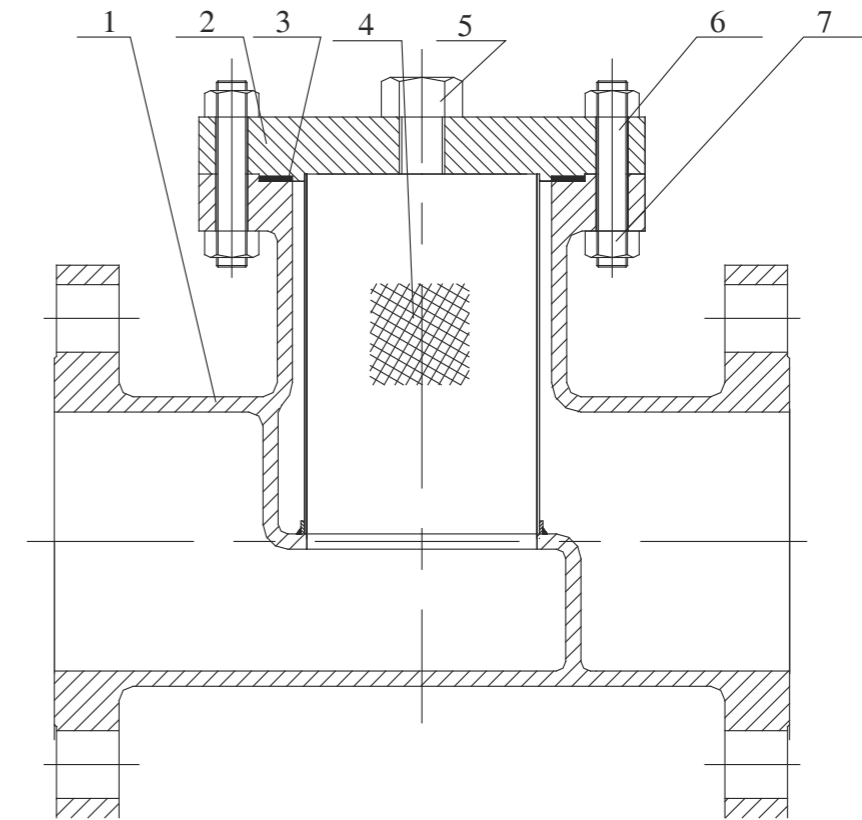

STAN DARDS:

- DESIGN AND MANUFACTURE: ASME B16.34
- FACE TO FACE DIMENSIONS: ASME B16.10(CHECK VALVE/GLOBE VALVE)
- FLANGED ENDS DIMENSIONS:
 - NPS1/2"~24" ASME B16.5
 - NPS26"~36" ASME B16.47
- PRESSURE-TEMPERATURE RATINGS: ASME B16.34
- PRESSURE: CLASS 150~300
- SIZE: NPS 2"~36"

BILL OF MATERIAL (PARTIAL)

ITEM	PART NAME	STANDARD	STAINLESS STEEL
1	BODY	ASTM A216 WCB	ASTM A351 CF8M
2	BONNET	ASTM A216 WCB	ASTM A351 CF8M
3	GASKET	SS304/SS316+GRAPHITE/PTFE	
4	SCREEN	SS304/SS316	SS316
5	PLUG	AISI 1025	SS316
6	BOLT	ASTM A193 B7/B7M	ASTM A193 B8M
7	NUT	ASTM A194 2H/2HM	ASTM A194 8M

NOTE: OTHER MATERIALS ARE AVAILABLE UPON REQUEST

T STRANIER

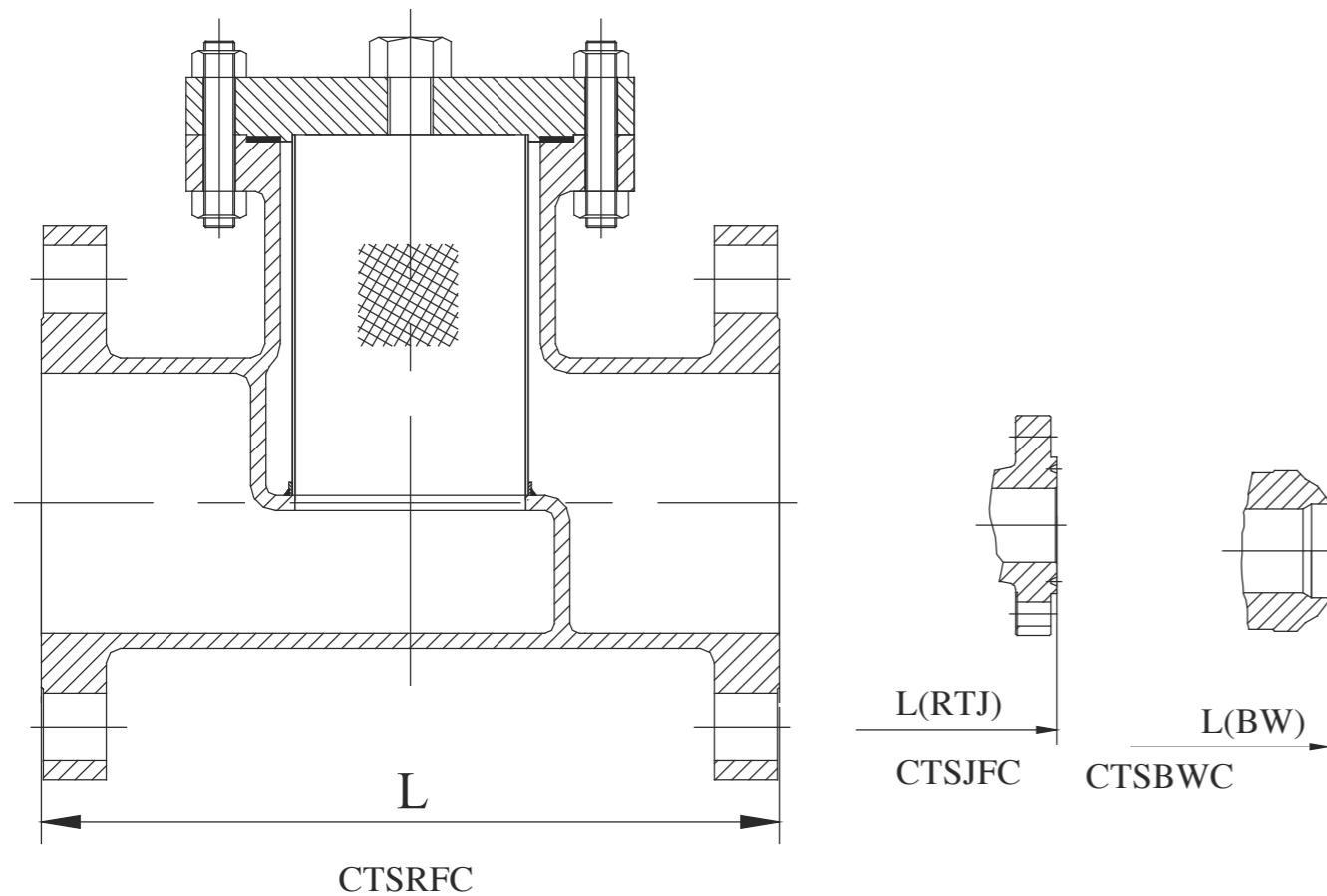

CLASS 150

NPS	in	2	2 1/2	3	4	5	6	8	10	12	14	16	18	20	24	30	36
DN	mm	50	65	80	100	125	150	200	250	300	350	400	450	500	600	750	900
L(RF)	mm	203	216	241	292	330	356	495	622	699	787	864	978	978	1295	1524	1956
L(BW)	mm	203	216	241	292	330	356	495	622	699	787	864	978	978	1295	1524	1956
L(RTJ)	mm	216	229	254	305	343	368	508	635	711	800	876	991	991	1308	1537	1968

CLASS 300

NPS	in	2	2 1/2	3	4	5	6	8	10	12	14	16	18	20	24	30
DN	mm	50	65	80	100	125	150	200	250	300	350	400	450	500	600	750
L(RF)	mm	267	292	318	356	400	445	533	622	711	838	864	978	1016	1346	1594
L(BW)	mm	267	292	318	356	400	445	533	622	711	838	864	978	1016	1346	1594
L(RTJ)	mm	282	308	333	371	416	460	549	638	727	854	879	994	1035	1368	1619

INSTALLATION, MAINTENANCE AND OPERATING INSTRUCTION STRANIER

1.0 Purpose

This instruction manual describes how to install, operation and maintain the strainer.

2.0 Application

The strainer should only be used for the conditions as specified in the data sheet, ie duty and liquid details. In addition it has been designed for use with industry recognised cleaning solutions.

3.0 Installation

Each Strainer is shipped completely assembled and ready for installation. Please note the correct location of the “INLET TAG” in order that the unit is properly aligned prior to bolting up in the field. Check hold down lugs on the closure to assure a proper seal will be maintained during the operation of the unit. For units with bolted covers, check to assure all nuts are tight.

4.0 Operation

During operation, once proper installation has been accomplished, the units require special monitoring. The pressure differential across the stain must be observed periodically to determine when the filter has become sufficiently loaded with solids to warrant the cleaning of the filter. The maximum acceptable differential across the filter should be determined and preset prior to operation to assure trouble free operation.

5.0 Maintenance

5.1 Should it be necessary to open the cover of the strainer, to remove or replace the filter, care must be taken to assure that the pressure inside the unit has been reduced to atmospheric. Each hold-down lug on the closure should be loosened halfway, i.e. not removing the swing bolt from its position, until the line fluid begins to seep out which assures that the line pressure has been reduced. Units having bolted covers, loosen each nut slightly, before completely removing.

5.2 When placing the filter into the straining unit, care must be taken to assure that the filter is properly seated. Before closing the cover, the machined surface which will contact the o-ring must be thoroughly wiped clean to minimize scoring on the o-ring. The o-ring itself should be inspected also to assure that proper sealing will be accomplished. Once closed the hold-down bolts should be tightened in such a manner as to assure that the cover and o-ring rest squarely on the seating surface. Bolted cover design strainers have flat gaskets and the same care must be taken.



KASKO DEMİRÇELİK MAKİNE VE İNŞAAT SANAYİ TİCARET LİMİTED ŞİRKETİ

**Güzelyurt Mah. Mehmet Akif Ersoy Cad. No: 38 Gökdemir Plaza Kat: 3 Ofis: 24 Zip Code:
34524 Esenyurt / İSTANBUL**

Tel: +90 850 441 25 67

Cell: +90 541 699 01 34

info@kaskomakine.com

kaskomakine.com