

## 100X DIAPHRAGM TYPE REMOTE CONTROL FLOAT VALVE

### GENERAL

100X diaphragm type remote control float valve is one type of multi-functional hydraulic valve. It is mounted mainly on the inlet of pool or water tower, when water level reach to the set level, the float pilot valve controls the main valve to close the water inlet to stop water supply; when the water level drops, the float pilot valve controls the main valve to open the water inlet to supply water into the pool, achieving automatic water supply. 100X diaphragm type remote control float valve can control the water level accurately without pressure effect. 100X diaphragm type remote control float valve can be mounted according to the pool height and operating space freely, so it's convenient to maintain, adjust and inspect. It has very good sealing and long service life.

100X diaphragm type remote control float valve has reliable performance, high strength, sensitive operating. It is applicable to be mounted on the pipeline ( $\leq$ DN450).

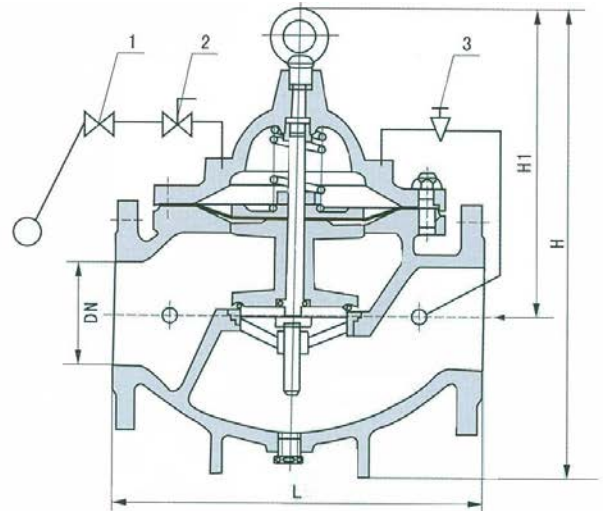

1. Float Pilot Valve, 2. Ball Valve, 3. Needle Valve

## TYPICAL INSTALLATION DIAGRAM

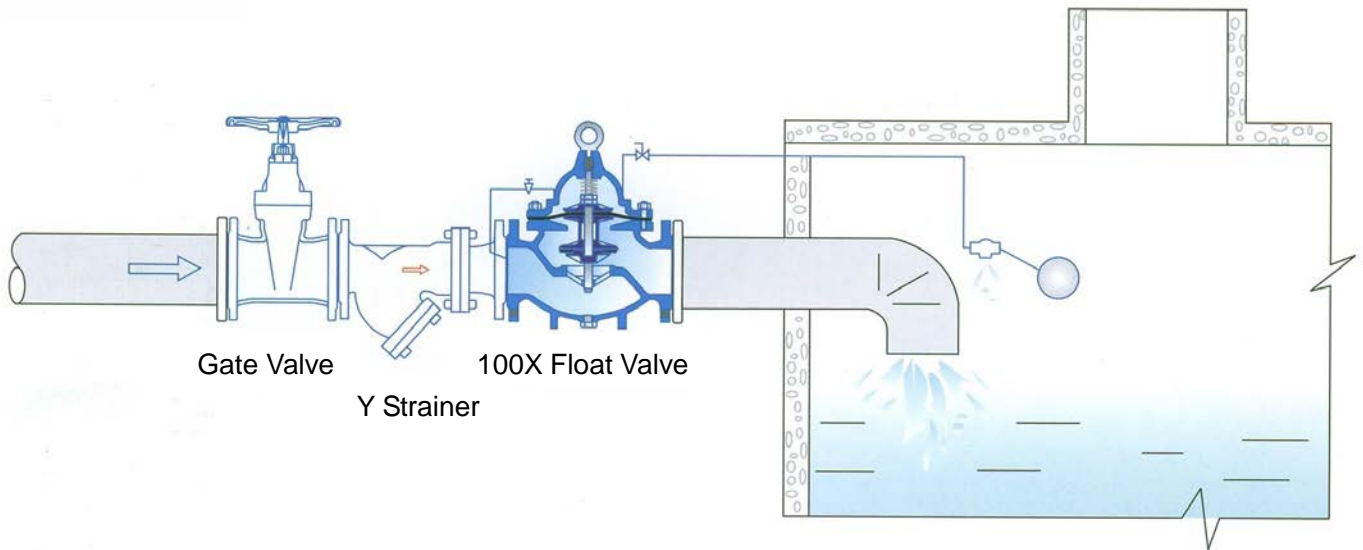

## EXTERNAL CONNECTION DIMENSIONS

| DN | 20  | 25  | 32  | 40  | 50  | 65  | 80  | 100 | 125 | 150 | 200 | 250 | 300  | 350  | 400  | 450  |
|----|-----|-----|-----|-----|-----|-----|-----|-----|-----|-----|-----|-----|------|------|------|------|
| L  | 150 | 160 | 180 | 200 | 203 | 216 | 241 | 292 | 330 | 356 | 495 | 622 | 698  | 787  | 914  | 978  |
| H1 | 179 | 179 | 179 | 210 | 210 | 215 | 245 | 305 | 365 | 415 | 510 | 560 | 658  | 696  | 735  | 735  |
| H  | 212 | 212 | 212 | 265 | 265 | 310 | 350 | 460 | 520 | 570 | 840 | 890 | 1030 | 1090 | 1150 | 1150 |

## 100X PISTON TYPE REMOTE CONTROL FLOAT VALVE

### GENERAL

100X piston type remote control float valve is applicable to be mounted on the pipeline ( $\geq$ DN500). Its disc is connected together with piston through the stem, its float pilot valve open and close controls the piston to move up and down, and then to achieve the main valve open and close.

100X piston type remote control float valve has safe and reliable operating performance, convenient adjusting and long service life.

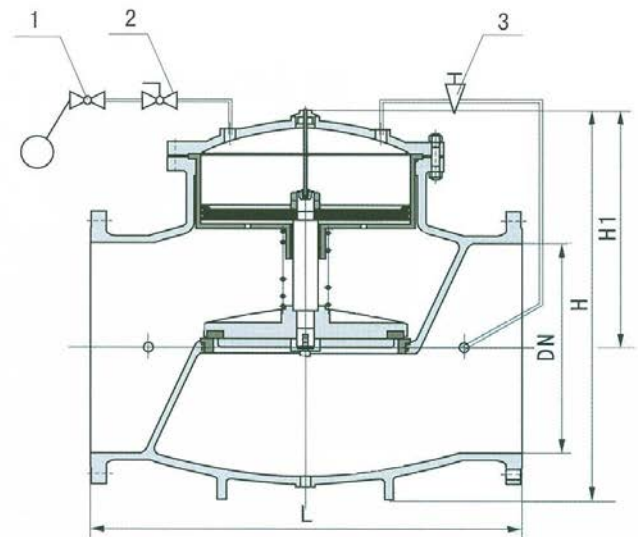

1. Float Pilot Valve, 2. Ball Valve, 3. Needle Valve

## TYPICAL INSTALLATION DIAGRAM

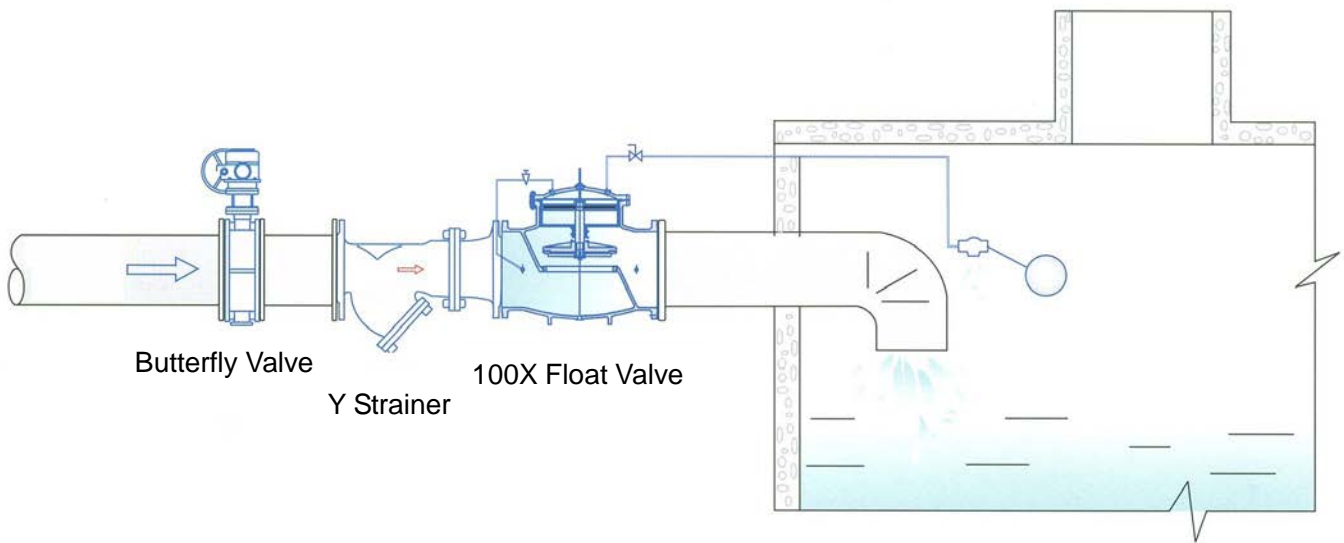

## EXTERNAL CONNECTION DIMENSIONS

| DN | 500  | 600  | 700  | 800  |
|----|------|------|------|------|
| L  | 1075 | 1230 | 1300 | 1450 |
| H1 | 620  | 695  | 930  | 950  |
| H  | 750  | 850  | 1120 | 1150 |



**KASKO DEMİRÇELİK MAKİNE VE İNŞAAT SANAYİ TİCARET LİMİTED ŞİRKETİ**

**Güzelyurt Mah. Mehmet Akif Ersoy Cad. No: 38 Gökdemir Plaza Kat: 3 Ofis: 24 Zip Code:  
34524 Esenyurt / İSTANBUL**

Tel: +90 850 441 25 67

Cell: +90 541 699 01 34

info@kaskomakine.com

kaskomakine.com