

It opens slowly and closes rapidly and is a normally closed valve complying with the UNI EN 161 Norm.

APPLICATIONS

- Gas interception on decompression units.
- Air/gas interception for burners.

CHARACTERISTICS

GENERAL:

- Working pressure: 360 mbar
- Fluid temperature: < 40°C
- Adjustable capacity: 0-100 %
- Voltage rating: 110/230 V 50/60 Hz
- Voltage (on request): 24 VAC/DC
- Tension tolerance: from -15% to +10%
- Working temperature: from -15°C to +60°C
- Opening time: from 4 to 25 s
- Closing time: < 1 second
- Coil direction: 360°
- Protection: IP 54 (EN 60529)
- Cable gland: M20 x 1,5
- Dust filter: incorporated
- Limit switch: on request
- Mounting: in any position except with coil facing downwards
- Manufactured in accordance to the EN161 Norm (EC certificate n. 0063AQ1350) in class A group 2.

MATERIAL COMPOSITION:

- Valve body: aluminum, copper, steel
- Seals: PTFE, NBR, FPM

DESCRIPTION

Solenoid valves are interception devices operating with auxiliary electrical energy suited for block maneuvers and gas or air supply in burners at atmospheric or blown air pressures, for furnaces and other applications that use gas as fuel. When the coil is not powered, the spring acts on the shutter, keeping the gas passage closed (intrinsic safety). In this condition, gas is present at line pressure in the inlet chamber and by pushing against the shutter it increases the sealing force. When the coil is powered, the valve opens slowly due to the hydraulic brake effect, overcoming the force of the spring and gas pressure. The part of rapid opening, and thus the initial flow, can be regulated by the special regulation screw. In the same way the flow and opening velocity can also be adjusted. If power is cut off from the coil, the valve closes rapidly, interrupting the gas passage.



F1111104

FLOWCHART

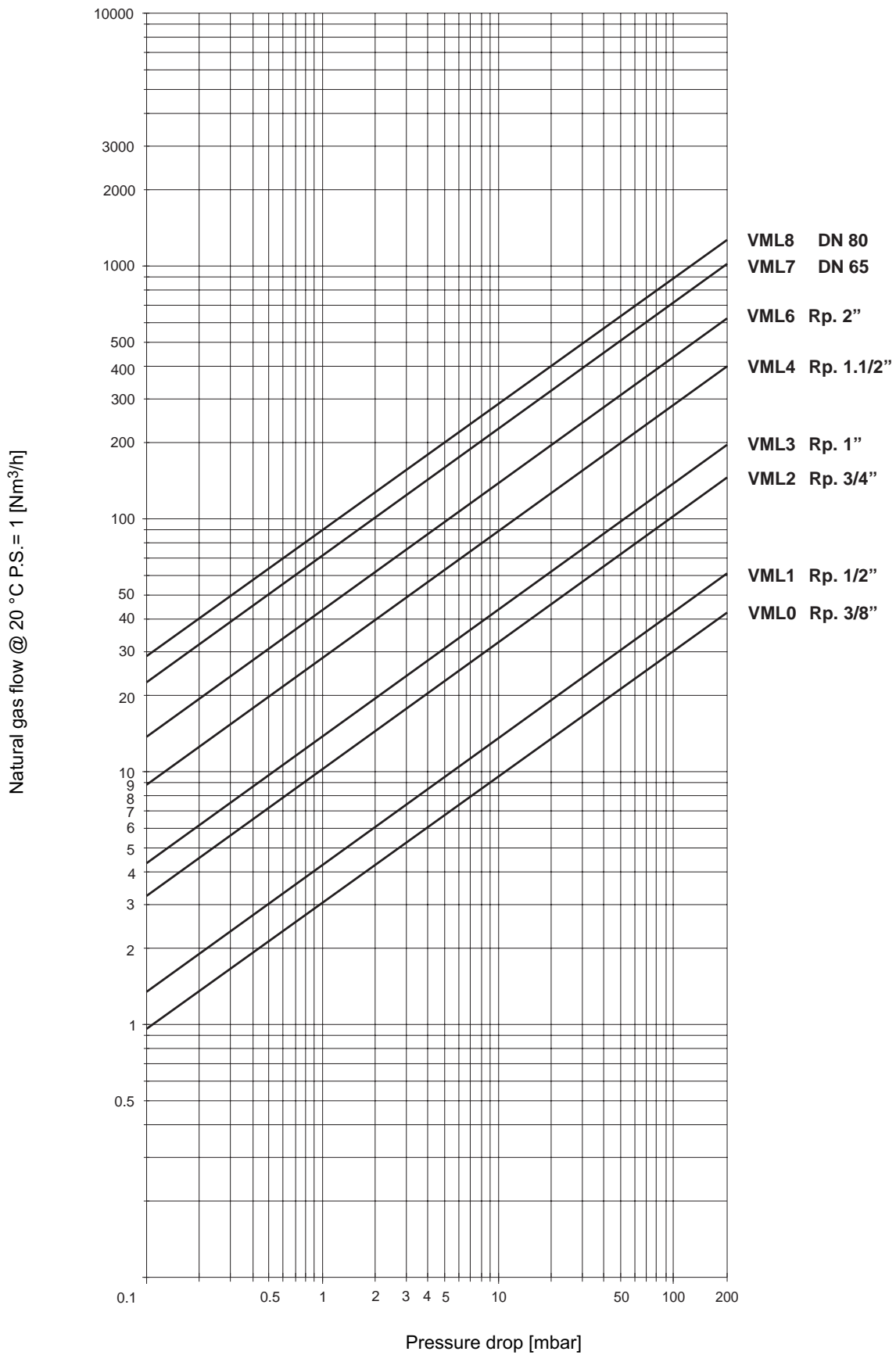

WARNINGS

- Make sure that the working pressure and fluid temperature are lower than the maximum values allowed.
- Check correct installation of the valve before starting the flow in the pipes.
- In case of valve malfunctioning, follow the indications

in the present manual at the “Maintenance” chapter.

- Any modification or repair done by third parties could compromise the application safety and cause the general warranty conditions to automatically expire.

INSTALLATION

Do not expose the valve to direct sunlight, heat sources or near combustion products, liquids, solvents or corrosive gases.

- Check that the line pressure is lower than the maximum working pressure allowed.
- Check that the arrow on the valve body is pointing in the correct flow direction.
- The valve may be installed in any position (coil can be horizontal or vertical), except with coil facing downwards.
- Ensure that there are no foreign objects inside the valve before assembling. If necessary, blow with compressed air.
- Check the correct alignment of the attachment pipes. Keep a certain distance from the walls allowing air to circulate freely.
- Leave enough space above the solenoid valve to extract the coil in case of replacement.

THREADED MODELS:

- 1 - Make sure that the threads conform to the valve that must be installed (**pos. 01**) according to the UNI ISO 7/1 Norm.
- 2 - Use thread-sealing paste on the male threads of the pipes (**pos. 02**) paying attention not to use too much as it could enter the valve and damage its seal.
- 3 - Screw the valve onto the pipe using an appropriate tool. Do not use the coil as a lever and only use the special seats on the body.

FLANGED MODELS:

- 1 - Weld the flanges (**pos. 03**) on the ends of the pipes, eliminating any welding burrs.
- 2 - Place the gaskets (**pos. 02**) between the flange (**pos. 03**) and the valve (**pos. 04**) and insert the bolts (**pos. 04**).
- 3 - Using appropriate tools, progressively tighten the bolts (**pos. 04**) crosswise.
- 4 - Avoid excessive tightening and mount without tension.

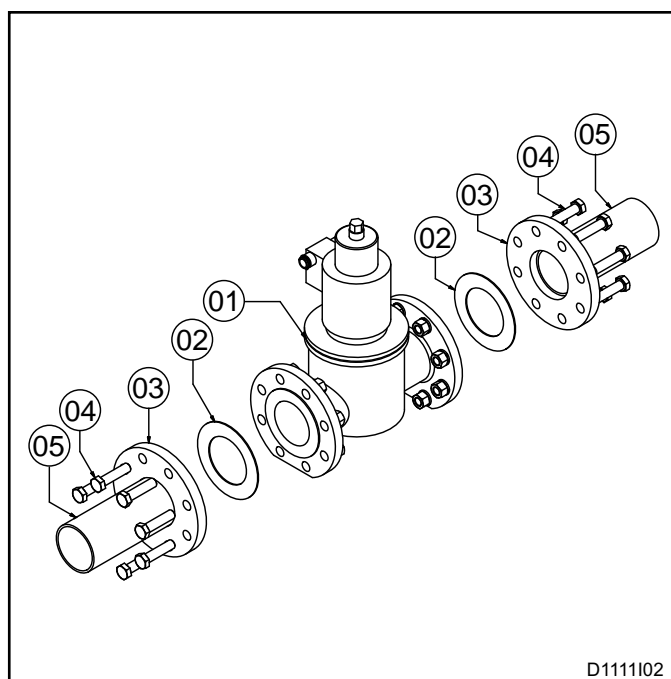
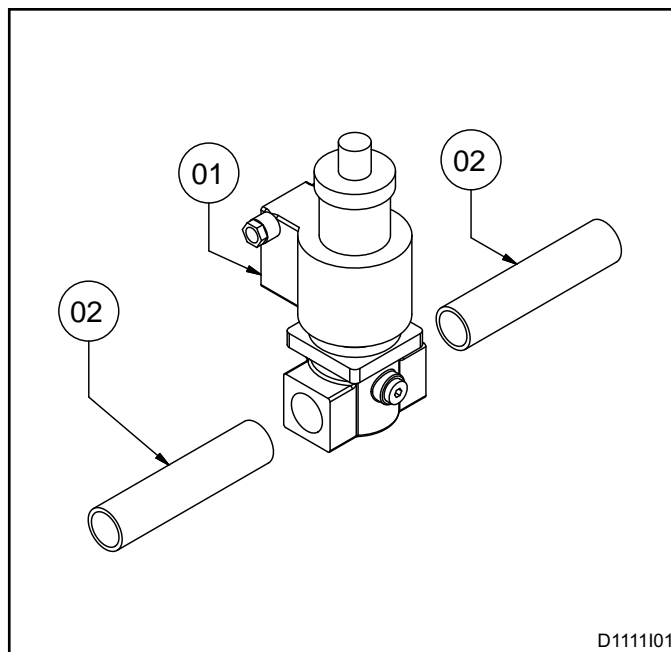

ELECTRIC WIRING

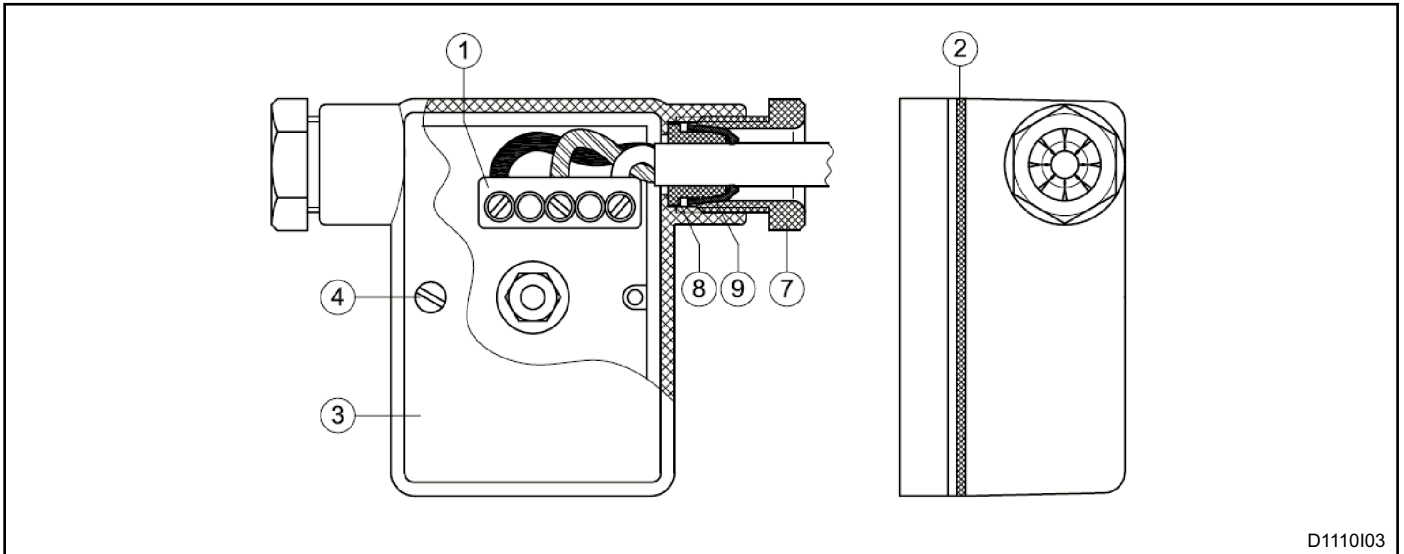

D1110I03

Before making any electrical connection, ensure that the voltage and frequency of the solenoid valve correspond to the electrical supply available.

- 1 - Disconnect electrical supply and close the gas.
- 2 - Using a screwdriver unscrew the screws (**pos. 04**) of the protection cover (**pos. 03**) of the connection box.
- 3 - Unscrew the cablegrip (**pos. 07**) and remove the locking ring (**pos. 09**) and the cone shaped gasket (**pos. 08**).
- 4 - Insert the cable respectively into the cablegrip, inside the locking ring of the cable gland, therefore inside the appropriate hole in the cover.
- 5 - Connect power to the terminals (**pos. 01**) of the recti-

fier circuit following the symbols indicated. In the case of valves powered at 12Vdc or 24Vdc, when the “+” terminals are used, do not invert polarity.

- 6 - Always make sure that the ground protection is connected to the related clamps (**pos. 01**).
- 7 - If the cable passage takes place through the hole that was originally closed, use the rubber pad under the cap to close the other hole if left open.
- 8 - Pull the wire and screw the cablegrip back on and then the cover, paying attention to position the gasket correctly (**pos. 02**).

REGULATION

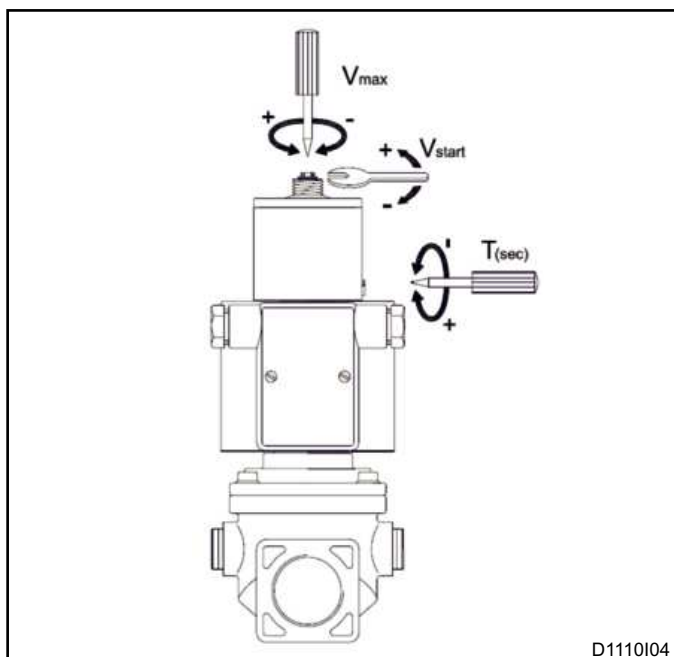

D1110I04

RAPID STROKE REGULATION (Vstart)

Once tested, the solenoid valves are supplied regulated at completely slow stroke with duration of about 14s. The rapid stroke time is regulated by unscrewing and removing the plastic cap found at the ends of the damper and intervening with a hex wrench turning the screw clockwise to decrease the stroke time or anticlockwise to increase it.

Each anticlockwise turn frees 1mm of the rapid stroke. The opening time and shutter stroke (with maximum flow) remain unchanged. After regulation, screw the plastic cap back on.

N.B.: In DN65 and DN80 models the minimum adjustable rapid part is 3mm.



REGOLAZIONE

FLOW REGULATION (Vmax)

The solenoid valves provided are adjusted to the maximum flow rate (regulation screw completely open). The flow can be regulated from 0m³/h to the maximum flow allowed.

Flow regulation is done through the inner screw underneath the plastic cap found on the valve damper. Unscrew and remove the cap and with the valve open (in voltage), keeping the external screw in place with a wrench, delicately turn the screw until you can feel the resistance against the nucleus. Starting from that position each clockwise turn decreases the flow of about 20% for 1/2", 12% for 3/4" - 1", 8% for 1 1/4" to 1 1/2" - 2". Rapid stroke regulations below 1mm and flow regulations below about 40% of the flow in the attachment pipes is not advisable as with variations in the line pressure this could create

problems in flow regime. After regulating, screw the cap on again.

OPENING TIME REGULATION (T)

To regulate the opening time one must intervene on the screw placed on the side of the damper. The standard time of 12-14 seconds is valid for almost all of the applications. In the anticlockwise direction, starting from the completely closed screw, in about two turns, 1/2" - 3/4" - 1" is reached, and in one and a half turns 1 1/4" - 1 1/2" - 2" is reached. Starting from the totally closed position each quarter clockwise turn increases the opening time by about 2-3 seconds and each 1/4 anticlockwise rotation decreases it by the same amount of seconds. Avoid forcing the limit switch as well as regulation over 25 seconds that could create turbulence during start-up.

ORDINARY MAINTENANCE

For correct maintenance of the VML solenoid valves, scrupulously abide by the following instructions. Before carrying out maneuvers with the plant on, make sure that the process and operator safety is not compromised. If necessary check with plant off.

INTEGRITY CHECK

■ The integrity of the gaskets and threads can be checked visually. If necessary, used liquid gas detector.

SOLENOID VALVE MOVEMENT

■ Checking for the presence of valve movement obstructions takes place by completely opening the valve and visually checking that there is nothing obstructing or limiting its stroke.

GENERAL MAINTENANCE PLAN

Maintenance and installation must be carried out by technically qualified staff respecting the Norms in force.

After installation has take place it is advisable to test the tightness of the threads or flange connections.

Operation	Type (*)	Advised time	Notes
Gasket integrity	O	annual	Check that there are no leaks outside
Thread integrity	O	annual	Check that there are no leaks outside
Maintenance of the solenoid valve	S	annual	Check the valve conditions

NOTES:

Key: O = Ordinary / E = Extraordinary

(*) it is suggested that the gaskets are replaced every time the valve is disassembled.



EXTRAORDINARY MAINTENANCE

For correct maintenance of the VML solenoid valves scrupulously follow the instructions with plant off.

Before proceeding with any type of installation or service, close the upstream gas supply and disconnect the power supply.

BOLT TIGHTENING

■ Checking the bolt tightening must take place when the plant is off.

GASKET REPLACEMENT

1 - Progressively unscrew the screws that fix the solenoid valve crosswise. Extract the solenoid valve and check the conditions of its internal components.

2 - Clean the inside of the valve body with a clean cloth and compressed air. Do not use tools that could damage the internal parts.

3 - Check that the valve moves without friction.

4 - Replace the gaskets and reassemble the valve in its seat, according to the steps indicated in the "INSTALLATION" section.

5 - Finally check that the valve moves freely without any obstructions.

COIL REPLACEMENT

Malfunctioning coils must be replaced. Disconnect electric supply, remove the junction box cover. Disconnect the cables from the clamps, unscrew the fixing cap and replace the coil reassembling the valve following the sequence backwards.

INTERNAL CLEANING

Dust and possible foreign objects can easily be removed from the filter or from the gas passage seat.

1 - Close the ball valve upstream of the plant.

2 - Remove the coil as described previously.

3 - Progressively unscrew the screws that fix the upper flange crosswise. During this operation some residual gas could leak out from the valve body.

4 - Check the condition of the o-ring gasket on the flange. If it is worn, see to its replacement.

5 - Clean the inside of the sleeve using a clean cloth and compressed air.

6 - Remove the return spring and blow it with compressed air. Pay attention to the mounting direction of the spring, that must be placed in the same way when reassembling.

7 - Clean the complete shutter assembly with a clean cloth and compressed air.

8 - Check the sealing gasket conditions. If it is damaged, replace it.

9 - Clean the sealing disc valve seat with a clean cloth. Do not use tools that could damage it.

10 - Remove the filter and blow it with compressed air.

11 - Reassemble the valve following the sequence backwards.



OVERALL DIMENSIONS - VML

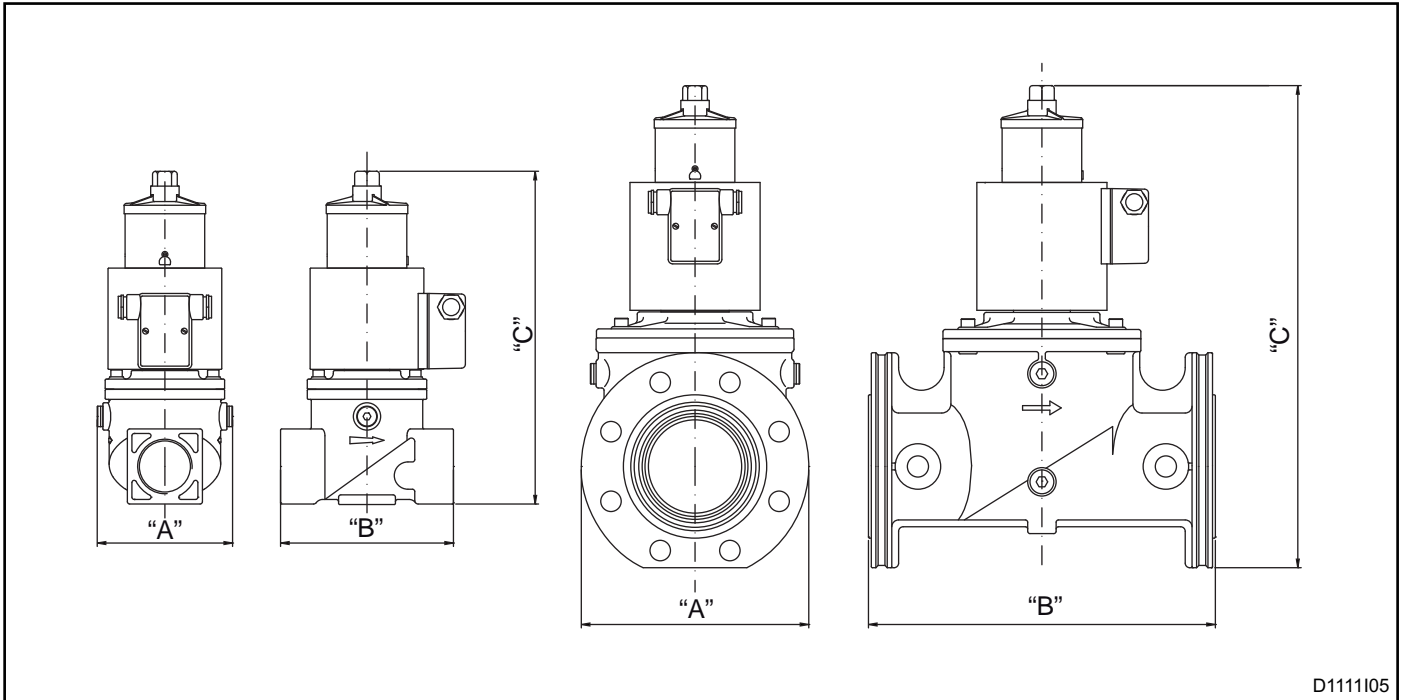

D111105

Model	Threaded attachments	Flanged attachments	"A" [mm]	"B" [mm]	"C" [mm]	Current drawn @230VAC [W]	Standard working pressure [mbar]	Available working pressure [mbar]	Mass [Kg]
VML0	G - 3/8"	-	88	77	196	20	500	200	1,8
VML1	G - 1/2"	-	88	77	196	20	500	200	1,8
VML2	G - 3/4"	-	88	96	222	45	500	200	2,7
VML3	G - 1"	-	88	96	222	45	500	200	2,7
VML4	G - 1.1/2"	-	120	153	294	45/180 (*)	500	200	6,2
VML6	G - 2"	-	106	156	304	45/180 (*)	500	200	6,5
VML7	-	DN65 PN16	200	305	424	60/240 (*)	200	360	14,5
VML8	-	DN80 PN16	200	305	424	60/240 (*)	200	360	14,5

(*) working / opening



ORDERING CODE - VML

VML - - -
01 02 03 04

Model		01
3/8" Rp. (DN10)	1	
1/2" Rp. (DN15)	2	
3/4" Rp. (DN20)	3	
1" Rp. (DN25)	4	
1.1/2" Rp. (DN40)	5	
2" Rp. (DN50)	6	
DN65	72	
DN80	82	

02 Voltage	
24 VDC	24DC (*)
24 VAC +10 -15%	24 (*)
115 VAC +10 -15%	115
230 VAC +10 -15%	230

03 Limit switch (*)	
Not installed	/
Present	PCS

04 Special applications	
No special	/
BIOGAS	J
CokeOvenGas COG	K

(*) on request





KASKO DEMİRÇELİK MAKİNE VE İNŞAAT SANAYİ TİCARET LİMİTED ŞİRKETİ

**Güzelyurt Mah. Mehmet Akif Ersoy Cad. No: 38 Gökdemir Plaza Kat: 3 Ofis: 24 Zip Code:
34524 Esenyurt / İSTANBUL**

Tel: +90 850 441 25 67

Cell: +90 541 699 01 34

info@kaskomakine.com

kaskomakine.com